

INSTRUCTION



HIND

MANUAL



1. INTRODUCTION	3	7. FLYING THE HIND	49
2. QUICKSTART	5	Handling modes	49
3. FLIGHT OPTIONS	7	Controls	52
Main Screen	7	Manoeuvres	54
Flight screen	8	Emergency procedures	58
Preferences	10	8. WEAPONS	61
Pilot's Log.....	13	Air-to-ground weapons	62
Scenario Selection	15	Air-to-air weapons	68
Single Missions.....	16	Delivery Techniques	71
Campaigns	16	Countermeasures	74
4. MISSION BRIEFING	19	9. MULTIPLAYER GAMES	75
Briefing Screen	19	Two player games	75
Mission planner	21	Set up for two player games	76
Mission Tips	24	Sending in-flight messages in two player games	81
Wingman and Formation Control	28	Network Games	83
5. COCKPIT	29	10. HIND - HISTORY AND DEVELOPMENT 85	
Pilot's cockpit	29	11. VEHICLE INVENTORY	89
Weapon systems operator's cockpit.....	39	12. CREDITS	93
6. VIEWING MODES	45	13. INDEX	95
Internal cockpit views	45	14. CUSTOMER SUPPORT	99
External views	45		
Forward Looking Infra Red (FLIR) view	46		
Low Light Level TV (LLLTV) view	47		
Turret optics view	47		

Copyright ©1996 Digital Integration Ltd.

All rights reserved. No part of this manual or software may be reproduced, stored in a retrieval system or transmitted in any form or by any means, electronic, mechanical, photocopying, recording or otherwise, without the prior permission of Digital Integration Ltd.

This product is exempt from classification under UK Law.
In accordance with The Video Standards Council Code of Practice it is considered suitable for viewing by the age range(s) indicated.



1. INTRODUCTION

The Hind. Known as the “bogeyman” by NATO ground troops, there is no equivalent in the Western inventory. The Mi-24 Hind has accumulated unrivalled combat experience, providing the backbone of first line assault helicopter regiments in at least nineteen nations. Deliveries of the Hind are known to have exceeded 2,300, with more than 1,250 deployed throughout the Soviet army. Designed to carry troops to the battlefield and support them with impressive firepower, the Hind has become a well-respected adversary of NATO forces.

Hind™ is a fitting sequel to our award-winning **Apache Longbow™**. The two products will link as the first step to Digital Integration’s **Virtual Battlefield™**. This is our first product to feature **ground troops**, providing a striking improvement to the sense of reality. We have introduced the new concept of the “**Silicon WSO**” - an intelligent crew member who will perform the functions of the Weapon Systems Operator in the front cockpit when you have your hands full just staying alive!

We have received much praise for Apache Longbow from our customers. They have provided valuable feedback, suggestions for improvements, “wish lists” and constructive criticism. We have included many of the requests and we are grateful for your comments. Thank you.

Before you begin, please read the **Installation Guide** carefully. It contains important information on how to install **Hind**.

Hind has been designed to entertain the widest audience possible. From the instant excitement of Quickstart to the authentic and challenging multi-mission Campaigns, there is something for everyone in **Hind**. Here is a summary of the treats in store:



Quickstart - throws you into the thick of the action from the moment you load Hind. Everything's hostile....

Training - a selection of missions designed to familiarise you with helicopter handling and all of the Hind's weapon systems. Training takes place at the **Saratov** air base in Russia.

Single missions - a total of thirty combat missions based in **Korea**, **Afghanistan** and **Kazakstan**. The missions include a wide variety of situations and tasks, each self-contained.

Campaigns - a multi-level, multi-mission campaign in each of the three combat zones. Your progress through a campaign depends upon the outcome of each mission, with a multi-threaded script setting the scene and assigning your tasks.

Two player options

- (i) **Combat** - allows you to fly head-to-head against a friend (or foe!).
- (ii) **Single Missions** - allows you to fly co-operatively with another player on any of the single missions, or Hind versus Apache with each player flying as aggressor or defender.
- (iii) **Pilot / WSO** - allows two players to crew the same Hind on all single missions. One player is the pilot, the other player the Weapon Systems Operator.

Network options

- (i) **Death Match** - up to sixteen players fight for survival - Hinds and Apaches
- (ii) **Capture The Flag** - a team game with the objective to destroy the enemy's headquarters

For your convenience, this manual is available on screen at any time - just press **S** 1 .



Quickstart Screen

2. QUICKSTART

Ready for action? Quickstart gets you airborne and over the battlefield as soon as the game has loaded. When running Hind for the very first time, the introductory sequence leads directly into the **Quickstart “Arcade”** mode, flying over hostile territory with your weapons armed. You have unlimited fuel, unlimited weapons, simplified controls and plenty of targets. There is no time limit but you can be shot down and it is possible to crash into the ground.

Push forward on the joystick (or press W) to accelerate and pull back on the joystick (or press Z) to slow down. Move the joystick left or right to bank and turn onto a new heading. Adjust your altitude with key Q to go up and key A to go down. You are over enemy territory so everything may be considered hostile. Let 'em have it.....

Weapons at your disposal include:

- 9M114 ‘Spiral’ air-to-ground missiles
- S5 57mm rockets
- 12.7mm turret-mounted machine gun
- R60 air-to-air missiles

Press *E* to select your weapon. The weapon name will appear on the head up display. Your “Silicon WSO” in the front cockpit will select targets and aim the weapon for you. All you need do is press *Z* to fire the weapon - and avoid getting shot down!

After using Quickstart for the first time, it may then be selected from the Main Screen. After clicking on Quickstart, you are presented with a choice of **Arcade** or **Invincible** mode, or the option to view the **Top Ten** screen.



Arcade: you have unlimited weapons, unlimited fuel and simplified controls. However, you can get shot down and may crash into the ground. You will be awarded a score during each flight depending upon how many targets you destroy.

Invincible: you have unlimited weapons, unlimited fuel and simplified controls. You are invulnerable to enemy fire and you will not crash if you hit the ground. No score is awarded in this mode.

Having chosen Arcade or Invincible, you must now select your scenario, Korea, Afghanistan or Kazakstan. Your flight begins as soon as the scenario is selected.

To end your flight press C and Q together.

Top Ten: This displays the top ten highest scores achieved in Quickstart Arcade mode. If your score is high enough to qualify for entry then a blank line will appear at the appropriate position. Type in your name to join the best of Hind pilots.

Although Quickstart defaults to novice controls, it is possible to use stable or realistic controls by selecting this option on the Preferences screen prior to selecting Quickstart. See chapter 3 for a description of Preferences.



“Scenario Select” Screen

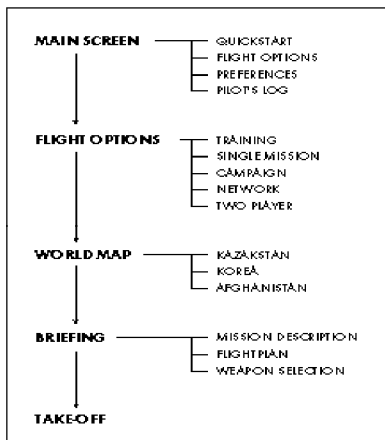

3. FLIGHT OPTIONS

Summary

This chapter describes the structure of the game, the various options available, the user-selectable preferences and the pilot's log.

Hind contains three combat areas: **Korea, Afghanistan** and **Kazakhstan** and one training area based at Saratov. Each combat area offers a choice of ten missions plus a multi-mission campaign. Use the training missions in order to become familiar with the flying qualities of the Hind helicopter and the various weapons systems that it carries. There are two Quickstart options, three two-player options and a network option for up to sixteen players. In total there are over one hundred and thirty missions.

Figure 3.0 shows the overall structure of Hind.

Main Screen

Use the mouse to click on any of the following options:

Quickstart - described in Chapter 2

Flight - click here to select the Flight Screen

Preferences - click here if you wish to alter your preferred settings

Pilot's Log - click here to start a new pilot's log or open/inspect an existing log

Each of these options is described in more detail below. You will also see two small buttons in the lower right corner of the screen:

Figure 3.0



Main Screen

GoTo

The 'GoTo' button appears in the lower right corner of every screen before take-off. Clicking here will open a window with the following functions:

Help - switches to the on-line manual

Preferences - switches to the Preferences screen

Logs - switches to the Pilot's Log screen

Quit - exits the game. You will be asked to confirm this selection.

Recognition - switches to the aircraft/vehicle recognition library

Main - returns the player to the Main Screen

Animations - click here to view animation sequences. Press any key to quit.

The function of the GoTo button is to enable you to skip from your present screen to whichever screen you wish and then to return to your present screen. For example, if during mission briefing you realise that you have not selected your pilot's log, the problem is remedied by clicking on GoTo, selecting Logs, selecting the correct Pilot's log and then returning directly to the mission briefing. Note: selecting Quit or Main from the GoTo menu will not return to the screen where GoTo was selected.

Quit

Click here to leave the game. This button is labelled **Exit** on subsequent screens. Click on Exit to return to a previous screen.

Flight screen

The Flight screen offers the following options:

Training - click here to display the list of training missions. Training always takes place at Saratov. Clicking on any of the mission titles will display a description of the mission, the number of helicopters involved, your



Flight Screen



targets and weapons to be used, your take-off time, flight time and the weather conditions. On training missions you may enable or disable **Infinite weapons** and **No Crashes** by clicking on the appropriate button. Click on **Commit** when you have chosen your mission. You will now proceed to Mission Briefing (see Chapter 4).

Single Mission- click here if you wish to fly a single, self-contained mission. Select a scenario (Korea, Afghanistan and Kazakstan) and you will be presented with a list of combat missions. Click on any of the mission titles to see a description of the mission, the number of helicopters involved, your targets and weapons to be used, your take-off time, flight time and the weather conditions. Click on **Commit** when you have chosen your mission. You will now proceed to Mission Briefing (see Chapter 4).

Campaign - click here if you wish to take part in a multi-mission multi-level campaign. Select a scenario (Korea, Afghanistan and Kazakstan) and you will arrive at the base of operations. At the beginning of your campaign you will be given a briefing of the overall scenario and you will be updated of progress before each flight. Click on **OK** when you are ready to proceed to Mission Briefing (see Chapter 4). Your success or failure on each mission will determine how the campaign progresses. After any flight you may leave the campaign by clicking on **Exit** and return to continue later. Your pilot's log will show the status of the campaign.

Network - click here to select the multiplayer network options.

(a) **Death Match** - Up to sixteen players fight for survival.

(b) **Capture The Flag** - This option pitches two teams against each other, with the objective of destroying the other team's headquarters.

A detailed description of the network games may be found in chapter 9 "Multiplayer Games".

Two player options - all two player games may be played using a modem, a direct serial cable link or across a network. Click here for the following options:

- (i) **Combat** - allows you to fly head-to-head against a friend
- (ii) **Single Missions** - allows you to fly co-operatively with another player on any of the single missions or against an Apache in Korea
- (iii) **Pilot / WSO** - allows two players to crew the same Hind on all single missions. One player is the pilot, the other player the Weapon Systems Operator.

A detailed description of the two player games may be found in chapter 9 “Multiplayer Games”.

Preferences

A number of program features are user-selectable and are collectively known as the Preferences. Depending upon your hardware configuration, the following options will determine how Hind runs on your computer.

Visual detail - In the upper left corner of the Preferences screen you will see the Visual Window. This demonstrates the level of visual complexity controlled by the slider bar beneath the window. Use the mouse pointer to drag the slider from minimum complexity at the left hand end to maximum complexity at the right hand end. Maximum complexity includes Gouraud shading, texture mapping, light sourcing and maximum visual range. The level of visual complexity will affect the “smoothness” of the simulation. Reduce the visual complexity if the simulation appears ‘jerky’.

Flight model - select between Novice, Stable or Realistic. The Novice flight model is much easier to fly if you are not familiar with the controls of a helicopter. The Stable model is far more representative of real helicopter handling but with secondary effects removed. The Realistic option includes the control cross-coupling inherent in helicopter dynamics.

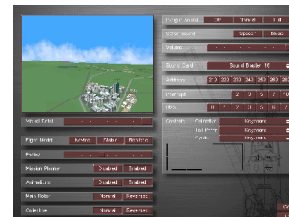

Preferences Screen



Enemy rating - select from Poor to Excellent by moving the slider bar from left to right. This “difficulty” factor will determine the effectiveness of the enemy e.g. awareness, aggressiveness etc.

Mission planner - with the mission planner Enabled many additional features are available for studying and changing your flightplan. These are described in detail in the chapter ‘Mission Briefing’.

Animations - a number of animation sequences are played throughout Hind in order to ‘set the scene’. Users with slower machines may wish to Disable the animations.

In-Flight Sound - You may select in-flight sound effects as Off, Normal or Full. The Full setting includes all Normal sound effects plus in-cockpit radio chatter. Selecting Full sound effects may slow down the program on slower computers.

Other Sound - Speech and Music, each selectable as on or off. ‘Speech’ refers to the introductory briefing speech prior to each mission. ‘Music’ refers to a number of atmospheric musical compositions played throughout the game to correspond with screen selection and your mission performance.

Sound card - click here to view a list of sound card types. Select your card or its nearest equivalent.

Address - the program will automatically attempt to determine the address of your sound card. If the sound does not work, check your sound card manual and use this to specify the address.

Interrupt - the program will automatically attempt to determine the interrupt setting for your sound card. If the sound does not work, check your sound card manual and use this to specify the interrupt setting.

DMA - the program will automatically attempt to determine the DMA setting for your sound card. If the sound does not work, check your sound card manual and use this to specify the DMA setting.

Controls - use this to select the type of device that you wish to use for each of your helicopter controls. The Collective (up/down), Cyclic (pitch and roll) and Tail Rotor (yaw) controls are selectable as follows:

Collective	keyboard or throttle stick (or throttle wheel)
Cyclic	keyboard or joystick or Thrustmaster FCS or Flightstick Pro or Virtual Pilot Pro
Tail rotor	keyboard or pedals

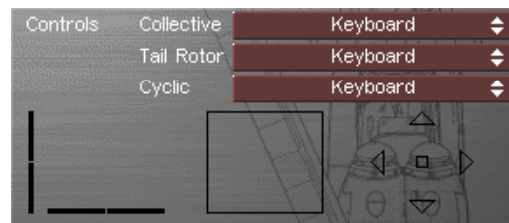

Figure 3.1

Figure 3.1 gives visual confirmation of joystick operation if selected, including the coolie hat if available.

Collective - click here to reverse the control sense when using a throttle stick.

Main rotor - click here to reverse the main rotor torque effects in the Realistic flight model.

All of your preferences are automatically saved to disc and will be preset automatically when you next load the game. Please note that all pilot logs use the same preferences.

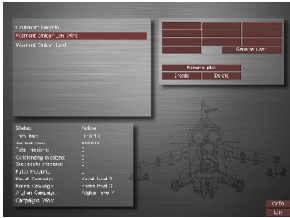

Pilot's Log Screen

Pilot's Log

Click here to select or begin a new pilot's log. The log supports up to ten users and each user may have up to ten pilot names. The first pilot name for each user is Comrade Immortal - a pilot with indestructible qualities. To enter a new user name, click on **Rename User** and type in your new name. To add a new pilot name, click on **Create** and type in your pilot's name. You may also **Delete** and **Rename** a pilot.

Each log will display information that is unique to each pilot's name:

Status

Active - normal status for pilot.

Injured - if you survive a crash in allied territory you may be declared injured for 24 hours.

Missing - if you survive a crash in enemy territory you will be declared missing for 48 hours.

POW - prisoner of war - if you choose to quit the mission after landing in enemy territory there is a chance that you will be captured. You will be released after 96 hours.

KIA - killed in action - if you do not survive a crash or get shot down on a combat mission.

KIT - killed in training - if you do not survive a crash on a training mission.

Note: time elapsed is taken from your system clock i.e. real hours.

Total time - total number of hours airborne on all types of mission.

Combat time - total number of hours airborne on combat missions.

Total missions - total number of missions flown, all types.

Outstanding missions - total number of missions on which you have achieved outstanding performance.



Successful missions - total number of successful missions.

Failed missions - total number of missions failed.

Campaigns - the log will also show which of the three campaigns are in progress and which have been completed.

Promotion through the ranks and medals are awarded as follows:

	No. of missions completed
Sergeant	0
Lieutenant	5
Captain	15
Major	30
Colonel	50

Order of the Red Star: Awarded after successful completion of two campaigns or one campaign and ten single missions.

Order of Lenin: Awarded after successful completion of all three campaigns or two campaigns and twenty single missions.

Gold Star (Hero of the Soviet Union): Awarded after successful completion of all three campaigns and all thirty missions.



*Order of the
Red Star*

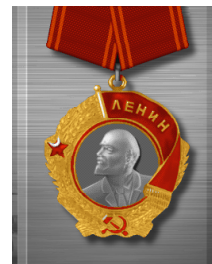

Order of Lenin

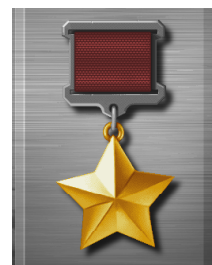

*Gold Star (Hero of
the Soviet Union)*



Scenario Selection

You have a choice of three scenarios - **Kazakstan**, **Korea** and **Afghanistan**. In Kazakstan both sides have Soviet equipment as you are fighting Soviet rebels. The Korean scenario involves both eastern and western equipment and it is here that you will meet the formidable Apache Longbow. In Afghanistan you are pitched against the resourceful Mujaheddin guerrilla forces.



Kazakstan



Kazakstan

Kazakstan is a republic in Central Asia, bordered by Russia to the north, China to the east, Kyrgyzstan, Uzbekistan and Turkmenistan to the south, and the Caspian Sea and Russia to the west. It is approximately five times the size of France and the second largest member of the Commonwealth of Independent States.



North Korea



North Korea

Located in north-east Asia, this is the northern half of the Korean Peninsula. It is bordered by China to the north, Russia to the north-east, the Sea of Japan to the east, and the Yellow Sea to the west. The capital city is P'yongyang.

Afghanistan

Afghanistan is a republic in south-west Asia, bordered by Turkmenistan, Uzbekistan and Tajikistan to the north, China, Jammu and Kashmir to the east, Pakistan to the east and south, and Iran to the west.

Single Missions

There are ten self-contained single combat missions in each scenario. There is no implied order of difficulty. We suggest that you complete a selection of the single missions before embarking upon a campaign.



Afghanistan

Campaigns

A campaign is a series of inter-linked combat missions. The outcome of each mission will determine how the campaign progresses. After any flight you may leave the campaign by clicking on **Exit** and return to continue later. Your pilot's log will show the status of the campaign.

The campaign scripts are based upon topical and historical information. The political and military tactics portrayed are totally fictitious.

Kazakstan Campaign - "Halt the rebellion"

Kazakstan has relocated its capital from the southern city of Almaty to the northern industrial city of Akmola. Over fifty per cent of the population of Akmola is Russian and twenty per cent Kazak. After nightmarish hyperinflation of 3000% in 1993, the Kazak government has succeeded in stabilising the economy and has reduced inflation to under 27%. The country is heavily dependant upon Russia for its electricity. In its desperate need for





foreign currency, Russia has raised the price of electricity and sabotaged Kazakstan's efforts to attract foreign investment needed to exploit their considerable oil and gas reserves and to build new power stations.

The failure of foreign investment has regrettably caused inflation to run out of control, with consequential unrest amongst Kazak government employees and the armed forces. The situation has deteriorated rapidly, with large sections of the Kazak army and air force under mutiny and their anger directed at the Russian population. The rebels have declared their intentions to overthrow the government and impose ethnic cleansing. In the capital city of Akmola there is now heavy fighting between the rebels and the loyal government forces. Large numbers of Russians are being driven from their homes. The Kazak government has requested Russian assistance to defeat the rebels and restore control. You are a member of the Russian helicopter assault squadron.

Korea Campaign - "Feed the People"

Korea has been divided into North and South since the Second World War. Restoration since the Korean war ended in 1953 has been difficult for both sides. With the assistance of Western nations, the South has concentrated upon economic growth and has continued to prosper with democracy established in 1987. North Korea became a closed and secretive society under the tyrannical rule of Kim Il Sung. Recent strained relations with China, the North's traditional ally, have lead to even greater isolation for President Kim Jong-il. A permanent peace treaty between North and South has never been signed and the North has publicly declared that it remains dedicated to invading the South. With military forces of both sides responding to the mounting tension, the border zone is recognised as one of the most dangerous in the world.

Flooding and storms have severely affected the grain harvest in the North. Thousands have been left homeless and starving but appeals for international assistance have brought little reaction. Faced with mounting pressure, the



North Korean government is directing its armed forces to invade South Korea. Recent military exercises along the border have prepared the North Koreans for the attack. Their first objective is to secure food supplies from storage facilities and distribution centres around the port of Incheon. Your role is to support the North Korean forces in the air power offensive.

Afghanistan Campaign - "The Second Kunar Offensive"

Set during the Russian occupation in 1985, you will be flying Hinds against a determined and resourceful foe: the Mujaheddin. Although mainly a foot-based guerrilla army, they are highly mobile and in the broken hilly terrain make very elusive targets. They are also armed with heavy machine guns, mortars, artillery, and SAMs.

Five years after the Russian invasion, the Russian and Kabul regimes are failing. Most of the countryside is controlled by the Mujaheddin with major towns and garrisons besieged. The situation is becoming progressively worse as the guerrilla's equipment, tactics and organisation improve. The territory gained in several major offensives into the countryside has not been held due to the amount of manpower required and casualties sustained.

The first Kunar offensive aimed to open the Jalalabad to Chagha Sarai road, securing it with garrison posts. Supply lines were to be cut, guerrilla forces destroyed in the Pech Dara, Asmar and Barikot areas, and the besieged garrison at Barikot relieved. Russian troops reached Chagha Sarai and reinforced garrisons in southern Kunar, but were forced to retreat to Jalalabad. This campaign begins the second offensive and you are required to contribute as a member of the Hind helicopter assault squadron.

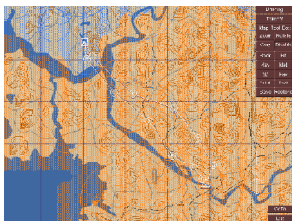

Briefing Screen

4. MISSION BRIEFING

Briefing Screen

Briefing

After selecting your mission, you will arrive at the Briefing Screen. Click on the **Briefing** button to open a window giving a full description of your mission. The window may be maximised or minimised by clicking on the button in the top right corner of the window. Click and drag on the slider bar on the left side of the window in order to scroll down to see more text if necessary. The window may be closed by clicking again on the Briefing button or by clicking in the top left corner of the window.

Clicking on any point on the map with the right mouse button will centre the map at the new position.

The flightplan for your mission has already been created for you and is displayed on the map. It is a series of lines connecting labelled circles and triangles. The flightplan is composed of waypoints and legs. Waypoints are fixed reference points in the flightplan, A,B,C, etc. and a leg is the path between one waypoint and the next. There are several waypoint types:

Departure - Always waypoint A, shown by a square box. This is your take-off point.

Turning - points in the flightplan where you change course. These are the most common type of waypoint. Labelled with capital letters B,C,D etc. and enclosed by a circle.

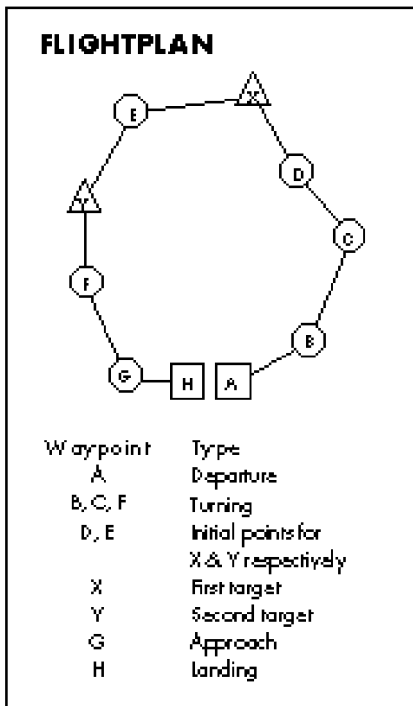

Figure 4.0



Initial point - a turning point prior to a target waypoint. This marks the beginning of an attack run. They are labelled in the same sequence as Turning points.

Target - location of planned target. Labelled with letters X, Y or Z in sequence and enclosed by a triangle.

Reconnaissance - you are expected to transmit reconnaissance data when reaching this waypoint by pressing key R.

Approach - the waypoint that marks the beginning of the approach to landing. They are labelled in the same sequence as Turning points.

Landing - the last waypoint in the flightplan, usually near to your take-off point. As soon as you click on **Take-off** you will proceed to the cockpit, with your aircraft armed and fully refuelled. The tower will give you clearance to take-off.

Ending or Aborting your flight

After touchdown at your landing waypoint you will be asked whether or not you wish to end your mission. Press **Y** to confirm, or **N** if you wish to continue. You may abort your mission at any time by pressing keys **C** and **Q** together. If you abort a flight you will not be able to save the mission in your pilot's log.

Debriefing

At the end of your flight you will return to this screen for a Debriefing. Your flightpath will be displayed for comparison with your flightplan and your mission effectiveness described. Click on **Exit** to leave the debrief. After a 'single mission', you will be asked if you wish to log the mission at this point. Select **Yes** to record the mission in your pilot's log. Select **Retry** if you wish to fly the mission again immediately without updating your log or **No** to return to mission selection. The option not to log or retry the mission is not

available during a campaign. You are expected to accept the consequences of failing to complete your mission.

Mission Planner

If the Mission Planner is enabled in the Preferences (see chapter 3) you will see the **Map Tool Box** at the upper right corner of the Briefing Screen. The tool box offers a number of functions that enable you to study and modify your flightplan, change the appearance of the Briefing Screen, alter your weapon payload and request a weather report. To select a function, click on its name with the left mouse button.

Zoom - use this function to magnify an area of interest. After selecting the zoom function the mouse pointer will change to the shape of a magnifying glass. Click and hold the left mouse button while dragging the mouse diagonally to define the area to be magnified. Upon releasing the mouse button, the specified area will be rescaled to fit the screen. Alternatively, clicking once with the left mouse button will zoom to a higher detail level at the position of the mouse pointer.

Back - click to return to previous zoom level.

Rotate - use this function to rotate the map about the centre of the screen. After selecting the rotate function the mouse pointer will change to a 'rotate' symbol. Click and hold the left mouse button and drag forwards / rearwards to rotate the map. This function can be useful for orientating yourself during the mission briefing.

Fit - click to resize the flightplan to fit the screen.

Way - click on this button to open the Waypoint window. Waypoints in your flightplan are listed in sequence. Information about a waypoint can be displayed by first clicking on the waypoint button and then clicking on **Info**. The Information window displays the following:

Briefing	
Takeoff	
Map Tool Box	
Zoom	Rotate
Way	Disable
Back	Fit
Key	Met
3D	Pay
Point	Task
Save	Restore

Map Toolbox

Position - x, y co-ordinates and altitude

Type - waypoint type: turning, target etc. as described above

Speed - the planned speed to the next waypoint

Start time - delay prior to take-off, in seconds

Time to this waypoint - time in hours, minutes and seconds, assuming planned speed

Clicking on any waypoint except the Departure point or the Landing point will cause the **Ins** and **Del** buttons to appear in the Waypoint window. To insert a waypoint in between two existing waypoints, first select the waypoint at the end of the leg to be modified, then click on **Ins**. A new waypoint will appear at the midpoint of the leg and the waypoints will be renamed. To remove a waypoint, first click on the waypoint symbol then click on **Del**. To move a waypoint, click and hold on the waypoint symbol and drag the mouse pointer to the required location. The first and last waypoint of any flightplan cannot be moved.

The x, y position, altitude and speed at any waypoint may be adjusted by clicking on the tiled digits in the Information window. Blank tiles will appear above and below the digit. Click above to increase and below to decrease. The Waypoint window is closed by clicking in the top left corner.

Save - If you have made significant changes to your flightplan, you may wish to save your work. Click on **Save** and the flightplan will be saved to your hard disc. When you select the mission again your modified flightplan will be loaded instead of the one supplied.

Restore - Click here to restore the original flightplan. **This will erase your modified flightplan.**

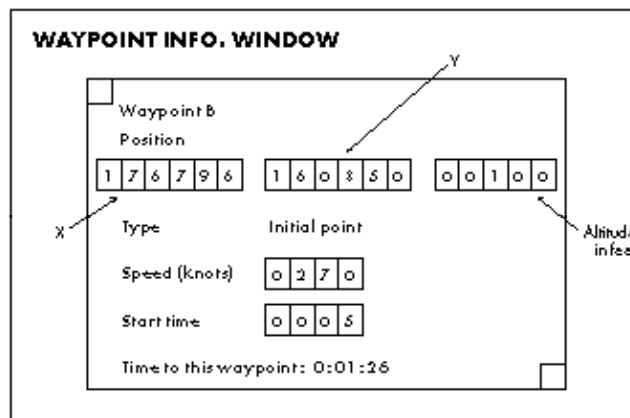

Figure 4.1



Task - If you have modified your flightplan, you may also wish to modify the flightplan of each wingman on your mission. Click here to open the Task window and click on each aircraft in the list to highlight its flightplan. You may modify each flightplan in turn. Use the Save button if you wish to save each new flightplan to your hard disc.

Point - click here to open the Point window. Position your mouse cursor anywhere on the map to discover (a) ground height, in metres, (b) ownership of territory, enemy or allied, (c) the type of object at the mouse cursor e.g. building, TV mast etc.

Disable - click here to disable the left mouse button. We advise that this be used prior to clicking on the **3D** button. This will avoid activating other functions such as 'zoom' while you are using the mouse to click on points of interest on the map.

3D - click on the Disable button before using this function. Clicking on 3D will open a small window containing a 3D visual display, used for exploring the map. The window may be resized by dragging the lower right corner and closed by clicking the top left corner. The window has three modes, selected by clicking on Fly, Point or Sat:

Fly - click on any point on the map after selecting this function. The 3D visual window will now "fly" to that location. If the left mouse button is held, the 3D view will fly to and follow the location of the mouse pointer.

Point - click on any point on the map after selecting this function. The 3D visual in the window rotates about that point, looking down at the ground.

Sat - click on any point on the map after selecting this function for a static vertical "satellite" view of the ground at that point.

Key - click here to display the map key. Click on the Key buttons to turn the following elements on or off:

Grid lines - scaled dependent upon zoom level.

Waypoints - display flightplan

Compass - displays compass symbol

Allied AAA - displays location and range of allied AAA

Allied SAM - displays location and range of allied SAMs

Enemy AAA - displays location and range of enemy AAA

Enemy SAM - displays location and range of enemy SAMs

Sides - applies shading to indicate division of allied/enemy territory

The Key window may be closed by clicking in the top left corner.

Met - click here to display weather information: wind speed, wind direction and visibility. Note that the wind blows FROM the specified direction e.g. a direction of 45 degrees will result in your helicopter drifting in the direction of 225 degrees.

Pay - click here to view the weapon payload display. Weapons appropriate to your mission will already be loaded, together with full fuel. Move the mouse pointer to each weapon to display its name. To remove weapons from the aircraft, click on the loaded weapon. To load a weapon or replace a loaded weapon, first click on the desired weapon lying in front of the helicopter. Possible loading positions for the weapon will be displayed e.g. inner pylon, outer pylon or wingtip pylon. Note that not all weapons fit on all pylons. Selecting the desired pylon will load the weapon on each side of the helicopter.



Payload Window

Mission Tips

General

Most missions have been designed with a cruising speed of 300kph between waypoints and a cruise altitude of 30m. This gives sufficient flexibility to adjust your speed and position relative to your wingmen. You must execute the required task given in your mission briefing and land at the last waypoint for a



mission to be successful. Performance over and above the mission requirements may earn an outstanding rating for the mission.

Unlike the **novice** flying mode, the **stable** and **realistic** modes do not have terrain following, and even the novice mode is not infallible when flying at high speed. Keep an eye on your radar altitude as you fly over hills - particularly at night.

When faced with an incoming missile or enemy anti-aircraft artillery, you are advised to turn sharply (jinking) and deploy chaff and flares. Flying low will decrease the likelihood of SAMs, particularly if you make use of terrain masking i.e. keeping below the horizon. Unfortunately, flying low will expose you to small arms fire.

Armoured formations engaged in battle occur frequently along the front line. These forces are accompanied by air defence equipment e.g. SAMs and AAA. If you are fired upon, take out the air defences first. Do not waste weapons destroying tanks unless this is the purpose of your mission.

You may change your weapon payload during your mission briefing if you prefer a different weapon mix. The turret machine gun has a very high rate of fire so use it in short bursts.

Prior to landing at the end of your mission, press **G** followed by **a** and **W** in order to obtain a look down view of your landing area. The airfield apron can be a busy place with aircraft, vehicle and personnel movements.

Training missions

Infinite Weapons - Clicking on “Infinite Weapons” will ensure that you will not run out of weapons during your flight.

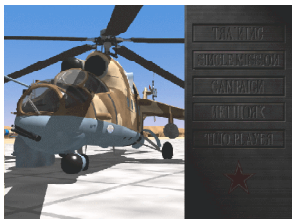

Training Screen



No crashes - Click on “No crashes” if you wish the game to ignore any crashes that would normally be fatal. We recommend that this option be used until you are familiar with Hind.

Watch out for other aircraft - The airfield at Saratov is a busy place. You will not be the only Hind pilot undergoing training so be prepared for other “rookie” pilots flying to and from the airfield apron.

Don't shoot the allies - Most vehicles, aircraft and buildings around Saratov are ALLIED. Targets are located only at target waypoints e.g. X and Y. Firing weapons at any other vehicles or buildings will result in mission failure. There are no enemy forces to contend with.

Troop deployment and evacuation - The Hind is capable of taking troops to the battlefield (deployment) and bringing them back (evacuation). After landing at the drop zone, press D to open the cargo doors. Troops on board will then deploy or troops waiting to be evacuated will climb onboard. You are at the wrong waypoint if the troops do not deploy.

To log or not to log? - As you leave the debrief screen after your flight, you will be asked whether or not you wish to log the mission. If you click on YES, the mission will be recorded in your pilot's log. NOTE: the log will become inactive if you crashed and died during the mission. If you click on NO, the outcome of the mission will be discarded and not recorded in your log. Click on RETRY if you wish to fly the mission again for whatever reason. Clicking on RETRY will discard the outcome of the mission just flown. This option is not available on Campaign missions.

Combat missions

Forward bases - A forward base is a temporary military installation (tents, supplies and vehicles) from where you will fly some of your combat missions. Be



prepared for the forward base to relocate between missions. Take note of nearby landmarks in case of navigation computer failure.

Reconnaissance - You will be expected to collect reconnaissance data when flying a reconnaissance mission. Press key R as you fly past the target waypoint. A confirmation message of "Good recon" will appear if successful. If R is pressed at the wrong point in your flightplan you will see the message "Recon bad".

Weapon reloading during your mission - Your Hind carries spare weapons when you are not deploying or evacuating troops. To reload, you must land and remain on the ground until you see the confirmation message "Weapons reloaded". Weapon reloading is automatic. Spare weapons will be of the same quantity and type loaded prior to take-off and will only be loaded onto the same pylon as at take-off. N.B. The Hind crew is not capable of reloading bombs. Spare bombs are not carried. If all spare weapons are not loaded when you land, you may land again to reload after the relevant weapons have been used. If you land after using all spare weapons you will see the message "No spare weapons".

Formation flying - There will always be at least one other Hind accompanying you on a combat mission. The nearest Hind to you at take-off is your wingman. Use C 1 to C 4 to issue commands to your wingman only. If you wish to issue commands to the entire formation use S 1 to S 4. Wait for clearance to take-off. Your formation will take-off typically a few seconds before you.

If your wingman or the formation comes under fire during the flight they will probably depart from the flightplan and retaliate. Try not to fly ahead of the formation when this occurs or else you will lose any defensive cover that they are able to provide when you reach the target area. Use the formation message "Resume flightplan" (S and 4) if the formation is distracted for too long.

When escorting Hip helicopters, the cruising speed will be approximately 240kph.



WSO target selection - When active, the WSO will make his best judgement of which target to select and track. If you wish to lock onto a different target press *B* to instruct the WSO to rescan for a different target or press *T* (Target Track) to lock onto targets along your line of sight.

The WSO will only lock onto enemy targets. This may be a little confusing in the Kazakstan missions where both enemy and allies have the same equipment and troops i.e. Russian.

Remote bombing - In this type of mission you are required to laser designate a target while other allied aircraft drop laser-guided bombs. Fly to the target area and illuminate the target by either selecting and tracking the target manually by pressing key *T* or by using the WSO. The allied aircraft carrying the laser-guided bombs will transmit messages confirming their approach to the target and bomb release. The bombs are released at high altitude and will take up to two minutes to strike the target. As this is a co-ordinated attack your time of arrival at the target is important.

Readme file - Be sure to check the Readme file on the CDROM for further tips.

Wingman and Formation Control

During flight you may issue the following commands to your wingman or to the entire formation. Your wingman is always the second Hind on the Task list when the Mission Planner is enabled.

	Wingman	Formation
Go home	<i>C</i> and 1	<i>S</i> and 1
Follow me	<i>C</i> and 2	<i>S</i> and 2
Attack my target/help me	<i>C</i> and 3	<i>S</i> and 3
Resume flightplan	<i>C</i> and 4	<i>S</i> and 4

5. COCKPIT

Introduction

The Hind cockpit is a two-seat tandem design with the pilot in the rear seat and the weapon systems operator in the front seat. The aircraft may be flown from either station but instrumentation is sparse in the front cockpit.

The light blue colouring of the instrument panel is common on Soviet aircraft. It is reported that aeromedical specialists discovered the colour to be the most soothing for Soviet aircrew.

Figure 5.0

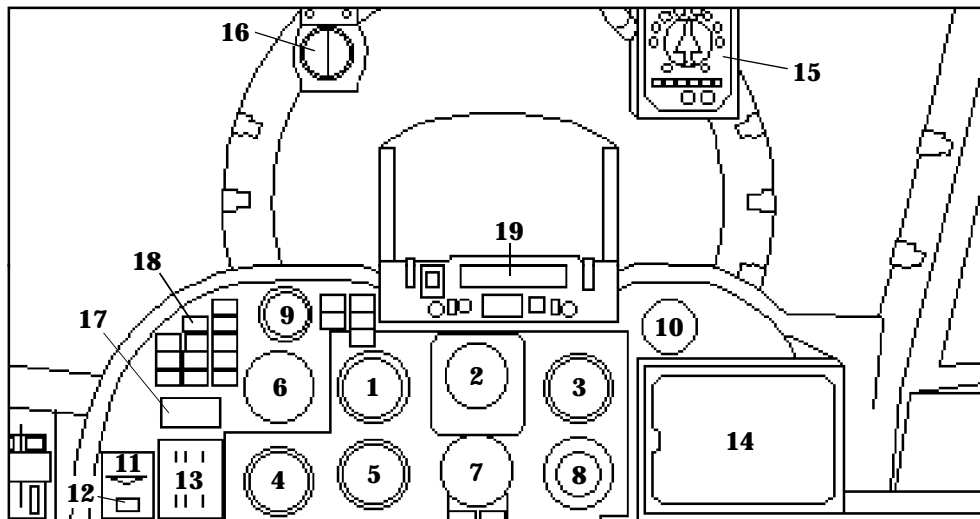

Pilot's Instruments

1. Airspeed indicator
2. Artificial horizon
3. Vertical speed indicator
4. Radar altimeter
5. Barometric altimeter
6. Pitch/Yaw/Roll indicator
7. Horizontal situation indicator
8. Standby artificial horizon
9. g meter
10. Clock
11. Landing gear indicator
12. Brake indicator
13. Engine and rotor rpm indicators
14. Moving map
15. Threat warning indicator
16. Standby compass
17. Fuel gauge
18. Failure warning lights
19. Text display



Pilot's cockpit

Press *h* or *2* to select the pilot's cockpit.

Pilot's instrument panel

1. Airspeed indicator (US-450K) - shows your Indicated Airspeed up to 450 km/hr. At sea level your Indicated Airspeed equals your True Airspeed. As altitude increases the reducing air density will result in your Indicated Airspeed being lower than your True Airspeed.

2. Artificial horizon (PKP-72M) - This instrument shows the pitch and roll attitude of your aircraft relative to the ground. For example, pitch up and the artificial horizon will fall. Roll right and the artificial horizon will roll left. This instrument also shows sideslip i.e. sideways velocity.

3. Vertical speed indicator (VAR-30MK) - show your rate of climb / descent in metres per minute divided by 10. Full scale deflection is 300 metres per minute. The needle will move clockwise from zero as you climb and anti-clockwise as you descend.

4. Radar altimeter (RV-5) - shows your height above ground level, up to a maximum altitude of 700m. Note that the scale is non-linear, displaying a higher resolution up to 100m.

5. Barometric altimeter (VD-10K) - shows your barometric altitude (height above sea level) in metres * 100 (large needle) and metres * 1000 (small needle). This will differ from your actual height above the ground when you are flying over hills. Each revolution of the large needle represents 1000m. Each revolution of the small needle represents 10,000m.

6. Pitch/Yaw/Roll indicator (VKT-2) - provides the pilot with an accurate display of pitch, roll and yaw. Used for aiming rockets.



7. Horizontal Situation Indicator (RMI-2) - this instrument has a rotating compass dial, showing your present heading at the 12 o'clock position. A pointer rotates to indicate the direction to your next waypoint. To fly towards your next waypoint, turn until the pointer is at the 12 o'clock position. The dial is calibrated 0 as due North, 9 as due East, 18 as due South and 27 as due West. Note: This is not necessarily your direction of flight as you may be flying sideways or even backwards. The bearing (degrees) and range (km.) to the next waypoint are displayed at the base of the instrument.

8. Standby artificial horizon - a back up used in the event of failure of the main artificial horizon.

9. g meter - shows g force due to aircraft manoeuvres. For straight and level flight the reading will show 1g. Maximum positive g force is +4g and maximum negative g force is -2g.

10. Clock - analogue clock

11. Landing gear indicator - three green lights confirms that the landing gear is down and locked. Three red lights confirm that the landing gear is retracting or extending. The lights go off when the gear is up and locked.

12. Brake indicator - a light immediately below the landing gear indicator illuminates when the brakes are ON.

13. Engine and rotor rpm indicators - three vertical scales calibrated from 0 to 120%: left engine rpm, right engine rpm, and rotor rpm. Engine rpm runs typically at 100%, with adjustments being made automatically. There is no manual throttle control.

14. Moving map - a rudimentary moving map display capable of tracking your position. The device is driven by the Hind's DISS-15D Doppler navigation system but does not orient itself with aircraft heading. Due North is always at the 12 o'clock position. Your position is pinpointed at the intersection of horizontal and vertical cursor bars. As the bars approach the edge of the display, the system recentres itself. There is no selectable scale.

15. Threat warning indicator - this display is mounted on the upper right of the cockpit framework. It is capable of informing the pilot that he is being tracked by enemy radar and also the direction of incoming missiles.

The display represents a plan view of your aircraft and consists of a central aircraft symbol surrounded by lights that give an approximate indication of direction of the threat. It is important to remember that the central aircraft symbol always points in the same direction as the nose of your helicopter. If a threat is shown at 3 o'clock then it is on your right hand side, no matter which way you are flying. Underneath the aircraft symbol are six classification lights depicting the type of threat:

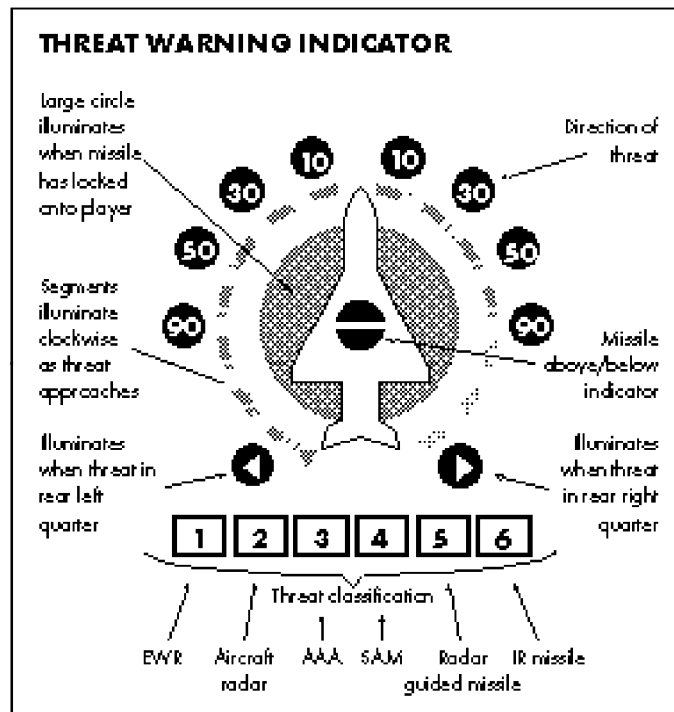

Figure 5.1

- 1 Early warning radar
- 2 Aircraft radar
- 3 AAA unit radar
- 4 SAM launcher radar
- 5 Incoming radar-guided RF missile
- 6 Incoming heat-seeking IR missile



A circle underneath the aircraft symbol will illuminate when a missile has locked onto you. Multiple threats are prioritised automatically. The classification light and direction indicator will illuminate for the greatest threat. The proximity of the greatest threat is depicted by an arc of small segments around the aircraft symbol. As the threat gets nearer, the segments will illuminate clockwise. Two semicircular lights at the centre of the aircraft symbol show whether an incoming missile is above or below you. You will also hear audio warnings from the Natasha system if you have in-flight sound effects enabled.

16. Standby compass - simple mechanical compass used in the event of failure of the horizontal situation indicator.

17. Fuel gauge - a digital display of your remaining fuel, in kgs.

18. Failure warning lights

NAV	navigation computer failure	LLTV	low light level TV sensor failure
ENG1	left engine failure	FLIR	forward looking infra red sensor failure
ENG2	right engine failure	GUN	gun failure
TORQ	engine overtorque	HMTD	helmet mounted target designator failure
RPM	low rotor rpm	LAS	laser designator failure
COM	radio / communications failure	FUEL	fuel low / fuel tank damaged
JAM	infra red jammer failure	U/C	Undercarriage failure
TWI	threat warning indication failure	FIRE	engine fire
HUD	head up display failure		

19. Text display - inflight messages

Head Up Display

The Head Up Display (HUD) is a unit mounted centrally in the pilot's cockpit above the instrument panel. Essential flight information is projected in his line of sight enabling him to maintain concentration on the view ahead. The Head Up Display has two modes:

(i) **Nav mode** - for navigation. This mode is displayed when weapons are "safe".

(ii) **Weapons mode** - for weapon aiming. Displayed when weapons are "armed".

Press *E* to select Weapons mode. Press *C* and *E* to select Nav mode.

(i) Nav mode

This mode displays your aircraft speed, altitude and other important information. (see figure 5.2)

True airspeed - your actual speed relative to the air, in km/hour. This must not be confused with Indicated Airspeed as shown on the instrument panel. At ground

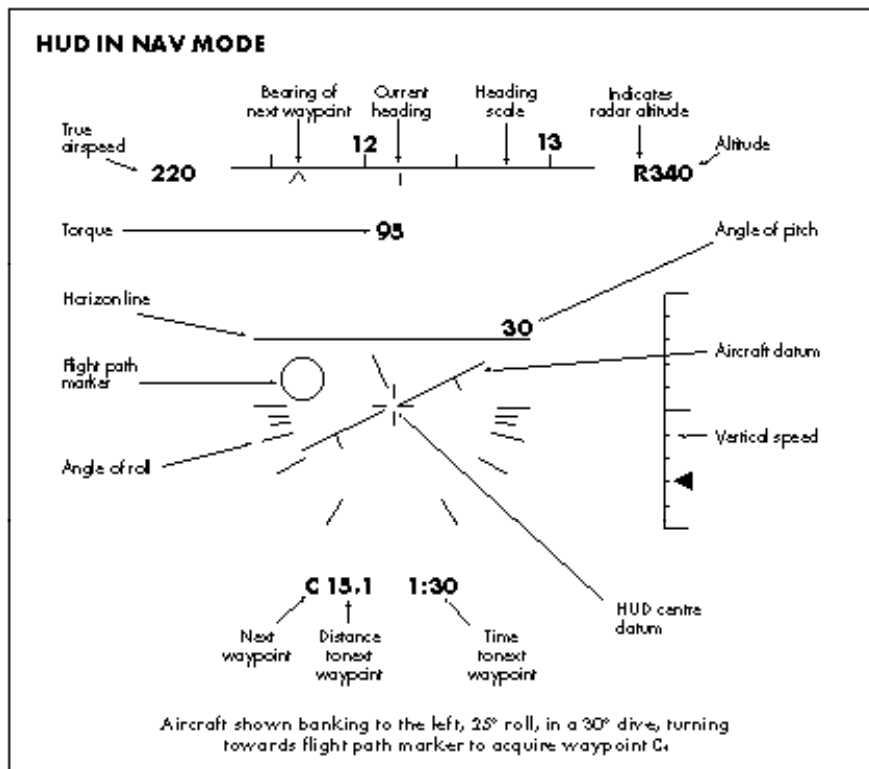

Figure 5.2



level, True Airspeed is the same as Indicated Airspeed. As altitude increases, Indicated Airspeed becomes lower than True Airspeed due to the decreasing air density.

Altitude - shows the height of your helicopter above sea level (barometric altitude) or height above ground level (radar altitude), both in metres. Whenever you fly within 700 metres of the ground, the readout will switch automatically from “barometric” to “radar”, confirmed by the symbol R. When below 700 metres, the readout will vary as you fly over hills.

Heading - shows direction in which your helicopter is pointing, calibrated in units of 10 degrees. (e.g. 270 is shown as 27).

HUD centre datum - a fixed cross marking the centre of the HUD

Aircraft datum - shows the orientation of your helicopter relative to the horizon. The symbol rotates around the HUD centre datum.

Horizon line - a horizontal line that rises above or falls below the HUD centre datum to indicate climb or dive.

Angle of pitch - numeric readout of your present pitch angle.

Angle of roll - a semicircular scale around the HUD centre datum used to indicate roll angle. The first 15 degrees of roll are calibrated in 5 degree increments, then 30 degrees and 60 degrees.

Torque indicator - digital display of engine torque. This will normally approximate to collective lever position, unless you are in autorotation.

Vertical speed - a vertical scale showing your climb or descent rate.



Waypoint information - distance and time to your next waypoint.

Flight path marker - a small circle that indicates bearing and relative altitude of your next waypoint. If the flight path marker is higher than the HUD centre datum, you are lower than the altitude planned for the current waypoint leg and you need to climb. If it is lower than the HUD centre datum you should descend. If it is to the left of the HUD centre datum you should turn left, and so on. If the flight path marker is over the HUD centre datum then you are flying directly to the waypoint at the correct altitude.

(ii) Weapons mode

The symbology displayed depends upon which weapon is armed and whether or not the WSO is using his Helmet Mounted Sight. In addition to the heading scale, airspeed and altitude readouts, and the aircraft datum, you will see the following symbols

Weapon - shows weapon selected and number remaining

Aiming reticle - replaces the flight path marker. (see figure 5.3a). This is your weapon "sight". Its position on the HUD will usually be determined by the WSO as he looks for and tracks targets. Cross-hairs are superimposed upon the Aiming Reticle when a tracked target enters the field of view of the laser designator (figure 5.3b) If the aiming reticle is out of the field of view of the HUD, then it will appear clipped at the appropriate edge of the HUD.

Weapon range scale - shows minimum and maximum range of currently selected weapon and also the range to the target if it is illuminated by the laser range finder.

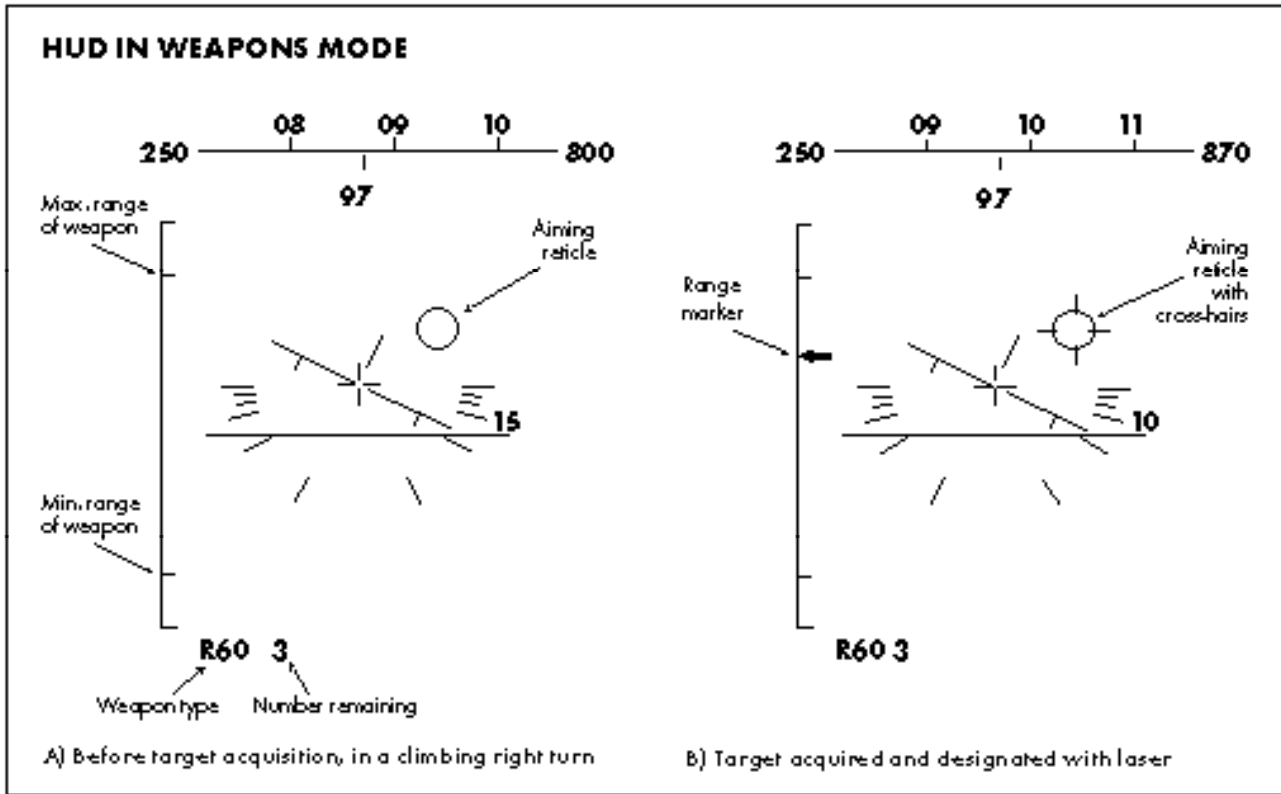

Figure 5.3

A more detailed description of the weapons symbology may be found in Chapter 8, "Weapons".



Natasha system

This is an audio warning system based upon a digitised female voice. Warnings are given to the pilot under the following conditions:

System failures:

- “Warning, navigation computer failure”
- “Warning, left engine failure”
- “Warning, right engine failure”
- “Warning, hydraulic pressure failure”
- “Warning, engine over-torque”
- “Warning, low rotor rpm”
- “Warning, communications failure”
- “Warning, infra red jammer failure”
- “Warning, threat warning indicator failure”
- “Warning, head up display failure”
- “Warning, low light level TV failure”
- “Warning, FLIR failure”
- “Warning, gun failure”
- “Warning, helmet mounted sight failure”
- “Warning, laser designator failure”
- “Warning, fuel low”
- “Warning, undercarriage failure”
- “Warning, engine fire”

Threat warnings:

- “Enemy ground fire”
- “Early warning radar illumination”
- “Aircraft radar warning”
- “SAM radar warning”
- “AAA radar warning”
- “Incoming RF missile”
- “Incoming IR missile”

Weapon systems operator's cockpit

Press *u* or *3* to select the WSO's cockpit.

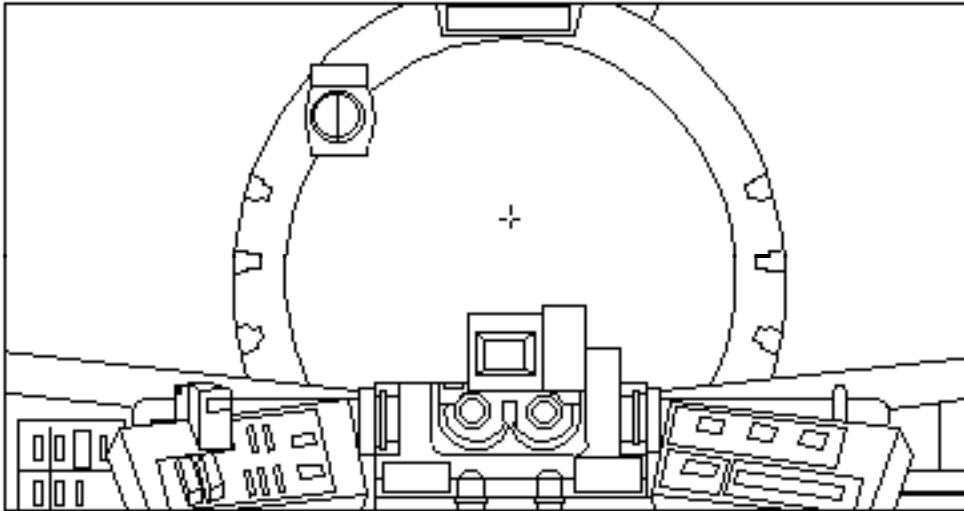

Figure 5.4

Silicon WSO

In the heat of combat, both pilot and the weapon systems operator (WSO) have much to do. In order that you may fly **Hind** single-handedly, we have introduced the “silicon WSO” - a reasonably intelligent computer-controlled Weapon Systems Operator. It is not compulsory to use him. In fact, you may “switch him off” if you wish to perform all the WSO tasks yourself. Use key *S* to toggle the silicon WSO on/off. When he is “on” he will search for targets, aim the weapons for you and fire on your command. If you select the WSO cockpit when he is active, the view from the cockpit will turn when he tracks targets. If you override his searching with the *a* and cursor keys



COCKPIT

then he will switch off. He will also verbally confirm targets as they are identified. He will not select weapon type. This remains your responsibility.

Weapon management panels

Offset to the right and left in the WSO's cockpit are the weapon management panels. (See diagram 5.4)

(a) Right panel - lists the weapons being carried on the current mission. Indicators show which weapon is selected.

(b) Left panel - shows the number of chaff and flares available.

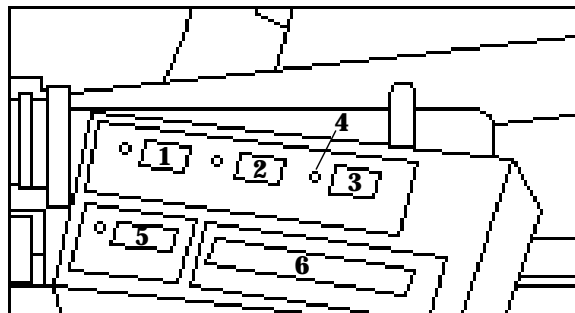

Right Panel

1. Inner pylon
2. Outer pylon
3. Wing tips
4. 'Selected' light
5. Rounds left in gun
6. Currently selected weapon

Other instruments

On the left side of the WSO's cockpit is a small panel of analogue instruments. Press *a* together with left cursor key to rotate your view to the left. The instruments are duplicates of those in the pilot's cockpit, described above. From left to right:

Barometric altimeter

Vertical speed indicator

Airspeed indicator

Radar altimeter

Standby compass - mounted on the canopy framework.

Helmet Mounted Sight (HMS)

The Helmet Mounted Sight is available only to the WSO and only when he is in normal cockpit view i.e. not viewing through FLIR, LLLTV or the Turret Optics. You must be in the WSO cockpit if you wish to control the helmet mounted sight.

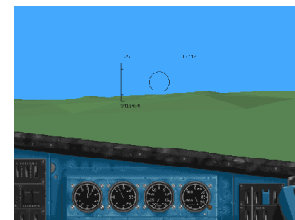

Analogue instruments

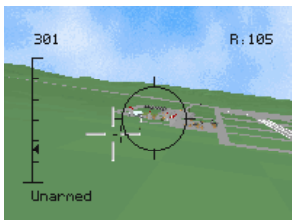

HMS reticle

The Targeting Circle shows the line of sight of the WSO. As your view direction is turned left or right, using *a* and cursor keys or *a* and joystick, the circle will remain at the centre of your field of view. Vertical adjustment using *a* and up/down cursor keys results in vertical movement of the Targeting Circle. To the left you will see the ranging scale, showing maximum and minimum ranges of the currently selected weapon, and the range to the target if illuminated with the laser designator.

The Targeting Circle may be 'locked' to a target by pressing key **T**. This equates to instructing the WSO to track the target. When a tracked target enters the field of view of the laser designator (approximates to the width of the pilot's HUD), cross-hairs will automatically appear on the Targeting Circle to confirm that the laser has designated the target. The weapon aiming system is then able to provide target ranging information to the left of the display.

Summary of how to use the Helmet Mounted Sight:

1. Select the WSO cockpit by pressing **3** or **u**.
2. Position the Targeting Circle over the target. To do this, the WSO uses *a* and cursor keys or *a* and joystick. This happens automatically if you use the Silicon WSO.
3. Select "track target" by pressing **T**. This happens automatically if you use the Silicon WSO.
4. Manoeuvre the helicopter to bring the target within the laser designator's field of view (approximates to the width of the pilot's HUD). Laser designation happens automatically and is confirmed by the appearance of cross-hairs on the Targeting Circle and range information appears to the left of the display.



Laser designator

This sensor is housed in one half of the electro-optical unit mounted underneath the nose of the Hind, on the starboard side. The laser is used to measure a target's range and position for weapon aiming, and also for guidance of the 9M114 'Spiral' missile in the terminal phase of its flight. The laser's field of view points directly ahead of the Hind, +/- 14 degrees left and right (the width of the pilot's HUD), 20 degrees up and 60 degrees down (to match elevation limits of the gun turret). The pilot must manoeuvre the helicopter to bring the target within the laser's field of view before ranging information can be displayed. Cross-hairs are superimposed on the Aiming Reticle or the Targeting Circle whenever a tracked target enters the laser's field of view. The laser designator is permanently on.

Forward Looking Infra Red system (FLIR)

The FLIR sensor system is mounted in the other half of the electro-optical unit mounted underneath the nose of the Hind. It provides the WSO with a monochrome full-screen view directly ahead of the aircraft for use at night. The display is used for target identification and weapon aiming. With a weapon armed, the display symbology includes the aiming reticle and ranging scale.

Summary of how to use the FLIR system:

1. Select the WSO cockpit by pressing 3 or u .
2. Select the FLIR display by pressing O.

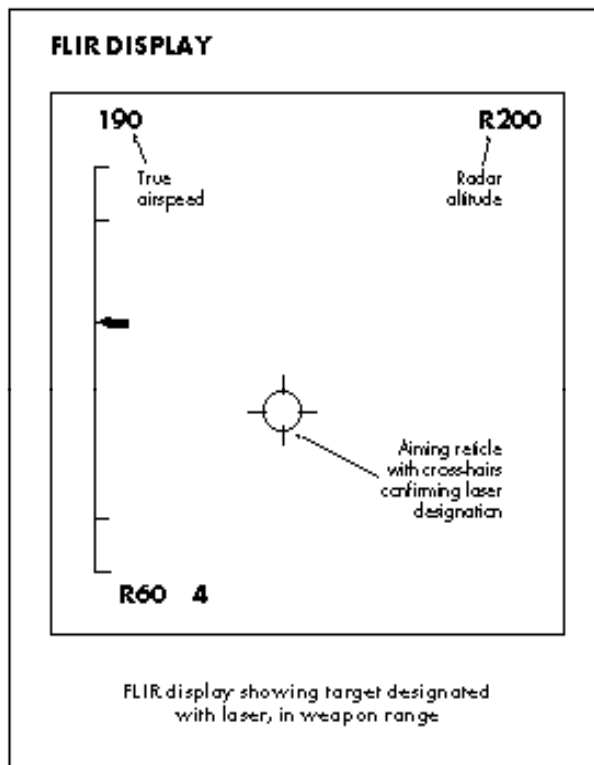

Figure 5.5



3. Position the aiming reticle over the target. To do this, the WSO uses *a* and cursor keys or *a* and joystick. This happens automatically if you use the Silicon WSO.
4. Select “track target” by pressing T. This happens automatically if you use the Silicon WSO.
5. Manoeuvre the helicopter to bring the target within the laser designator’s field of view. Laser designation happens automatically and is confirmed by the appearance of cross-hairs on the aiming reticle and range information appears to the left of the display.

Low light level TV (LLTV)

The LLLTV sensor unit is mounted in the same pod as the FLIR and is automatically fitted instead of FLIR when appropriate. The LLLTV is a monochrome full screen display. It is best used at dawn or dusk and becomes ineffective at very low light levels. The display is used for target identification and weapon aiming. With a weapon armed, the display symbology includes the aiming reticle and ranging scale.

Summary of how to use the LLLTV system:

1. Select the WSO cockpit by pressing 3 or u .
2. Select the LLLTV display by pressing O.
3. Position the aiming reticle over the target. To do this, the WSO uses *a* and cursor keys or *a* and joystick. This happens automatically if you use the Silicon WSO.
4. Select “track target” by pressing T. This happens automatically if you use the Silicon WSO.
5. Manoeuvre the helicopter to bring the target within the laser designator’s field of view (marked on the LLLTV display). Laser designation happens automatically and is confirmed by the appearance of cross-hairs on the aiming reticle and range information appears to the left of the display.

Turret optics

Direct view optics mounted in the chin turret allow the WSO to look along the line of sight of the machine gun. This full screen view is selected by pressing *G* and is steered with *a* and the cursor keys or joystick. Steering limits are ± 60 degrees left and right, 20 degrees up and 60 degrees down. The smaller 'field of view' box moves around within the larger 'field of regard' box and shows the orientation of the turret relative to the centreline of the helicopter (see figure 5.6). Although the Turret Optics are used primarily with the machine gun, they can be used with any weapon. Note: the aiming reticle remains at the centre of the field of view as the turret moves.

Summary of how to use the Turret Optics:

1. Select the WSO cockpit by pressing *3* or *u*.
2. Select the Turret Optics by pressing *G*.
3. Position the aiming reticle over the target. To do this, the WSO uses *a* and cursor keys or *a* and joystick. This happens automatically if you use the Silicon WSO.
4. Select "track target" by pressing *T*. This happens automatically if you use the Silicon WSO.
5. If you require ranging information, manoeuvre the helicopter to bring the target within the laser designator's field of view. Laser designation happens automatically and is confirmed by the appearance of cross-hairs on the aiming reticle and range information.

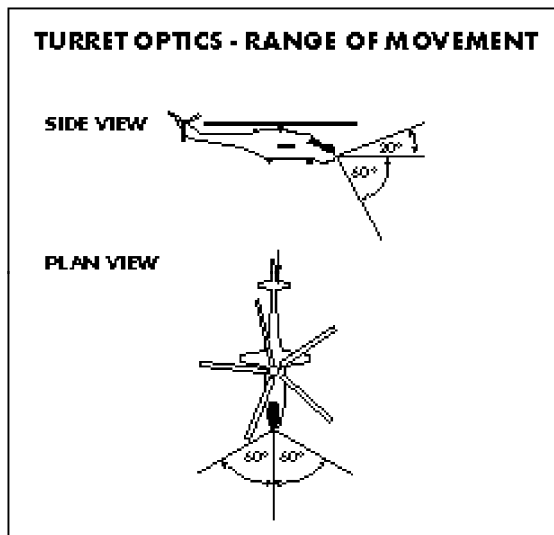

Figure 5.6

6. VIEWING MODES

Internal cockpit views



Internal cockpit view

Select the view from the pilot's cockpit by pressing z or h . You may rotate your view continuously through 90 degrees left or right by pressing a together with the left or right cursor keys. The view is centred by pressing key j . Select the Weapon systems operator's cockpit by pressing 3 or u . The viewing angle in each cockpit is independent and is "stored" as you move between cockpits.

Your view from the pilot's cockpit at night may be enhanced by pressing key v to activate the night vision goggles.



Tracking view

External views

Tracking view

Press 6 to view your helicopter from the Tracking viewpoint. The position of the view point may be rotated about the aircraft using a together with the cursor keys (or joystick), zoomed in with key $>$, and zoomed out with key $<$.

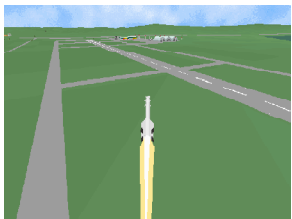

Weapon view

Weapon view

Press 7 to view from the weapon most recently launched. Rotate and zoom controls as above.



Target view

Target view

Press 8 to view incoming weapon from behind the target.

Target lock view

Press \ominus to look towards your locked target from outside your aircraft. When you are heading directly towards your target you will be viewing yourself from the rear.

Remote view

Press \bigcirc to fix your viewpoint at the current location of your helicopter. The view rotates to track your aircraft as you manoeuvre.

Spectator view

Press $-$ to fix your viewpoint at the current viewpoint location. Rotate and zoom controls as above.

Drone view

Press $=$ to cycle your viewpoint through various computer-controlled “drones”. Rotate and zoom controls as above. Press S and $=$ to reverse cycle.

Forward Looking Infra Red (FLIR) view

Available only to the weapon systems operator, this is a monochrome full-screen viewing mode selected by pressing key \bigcirc . The system is designed for use at night. It is ineffective in conditions of thick fog or during the day when contrast levels will be too low. The field of view is fixed directly ahead of the aircraft.



Target lock view



Remote view



Spectator view



FLIR view

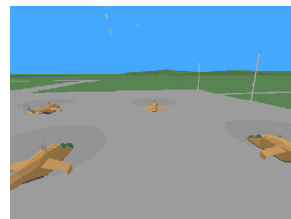

Drone view

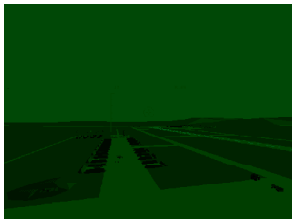

LLLTV view

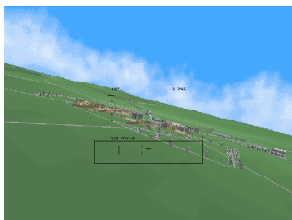

Turret optics view

Low Light Level TV (LLLTV) view

This system is fitted prior to take-off as an **alternative** to the FLIR and is available only to the weapon systems operator. This full-screen monochrome “image enhanced” viewing mode is designed for use in poor light conditions e.g. at dawn or dusk, but not at night when ambient light is insufficient for effective use. The field of view is fixed directly ahead of the aircraft.

Turret optics view

The turret-mounted machine gun is fitted with direct view optics, allowing the weapon systems operator to look along the line of sight of the machine gun. The view is represented by a full screen display with gunsight symbology superimposed. The turret is capable of traversing 60 degrees left and right, sixty degrees down and twenty degrees up. Press **G** to select this view and aim the machine gun by pressing **a** together with the cursor keys or joystick.

If the “silicon WSO” is enabled, he will aim the gun for you and you will see the turret view move of its own accord as the WSO searches for targets. If you choose to steer the turret view yourself you will automatically disable the “silicon WSO”.

This view is particularly useful as it allows you to look down and effectively “look through” the instrument panel in order to aim the machine gun.



HIND[®]



7. FLYING THE HIND

In most respects, the Hind is a “classic” helicopter in aerodynamic terms. There are few surprises in its handling characteristics and a good pilot will be aware of its strengths and limitations. Although technologically the Hind design is somewhat “dated”, during its life it has held eight world records for helicopter performance and has set eleven Soviet national records.

Handling modes

We have included three handling modes: **novice**, **stable** and **realistic**. If you are unfamiliar with the controls of a helicopter we suggest that you begin with the **novice** mode. Your chances of crashing are considerably reduced, allowing you to fly combat missions confidently within a short time. To allow you a greater degree of manoeuvrability without the complexity of control secondary effects, we suggest the **stable** mode. Finally, for those who like a challenge and will accept nothing less than the “full works”, we offer the **realistic** mode. With experience, you should become comfortable with either the **stable** mode or the **realistic** mode as these offer distinct agility advantages. However, aerobatic manoeuvres such as 360 degree rolls and loops are not possible in any of the modes - the Hind has a fully articulated main rotor making such manoeuvres impossible.

All references to the joystick in the following text may be interchanged with the four cursor keys. See “Primary flight controls” on the back cover of this manual.

Novice mode

To take off, press \uparrow to increase your altitude and press \downarrow to decrease your altitude. These keys represent the pilot’s collective lever that he uses to control his rate of climb and descent. In novice mode, this is your only means of adjusting your altitude. The rate of climb or descent depends upon how long the key has been pressed. As you press key \uparrow you should notice the torque readout increasing in the HUD.

The maximum recommended value of torque is 100% and this equates to the maximum climb rate. Pressing key A will reduce the torque readout (check the HUD as you press A) and if you hold the key long enough the torque will reduce to zero. If you are still airborne you will be descending at the maximum rate. If you wish to hover, adjust the torque readout to 50. This can be achieved by pressing key 5 (not the numeric pad). For convenience, collective settings are selectable on keys 1 to 0, representing torque values of 10% to 100%.

Once airborne and in the hover, push forward on the joystick to accelerate. The helicopter will tilt forwards and accelerate but it will not descend. Centralise the joystick when you have reached your desired forward speed. The top speed is approximately 335 kph.

When you wish to slow down, pull back on the joystick. The helicopter will tilt upwards but will not climb. Centralise the joystick when you have reached your desired speed. If you continue to pull on the joystick, you will eventually begin to fly backwards.

At low forward speeds or in the hover, moving the joystick left or right will roll the aircraft accordingly and cause it to fly sideways. When you centralise the joystick the helicopter will level out and any sideways speed will decay to zero due to the high aerodynamic drag of the fuselage.

Moving the joystick left or right at higher forward speeds will roll the helicopter and result in a turn onto a new heading.

At low forward speeds or in the hover, pressing Z or X will yaw the helicopter left or right. For example, if you press Z or X when in the hover you will turn on the spot. This represents your tail rotor control. The effectiveness of this control reduces as forward speed increases. By 130 kph the effectiveness will have reduced considerably.



Steep pitch and roll angles are not possible in the novice mode but the Hind is not aerobatic anyway. A major advantage of the novice mode is that the Hind will attempt to stay at the same height above ground, even when going over hills. This is a simple form of terrain following but some fluctuations in altitude will still occur depending upon how fast you approach a hillside. The system is not infallible. It is still possible to fly into a steep hillside at high speed.

Stable mode

This mode has much more authentic helicopter handling qualities than the **novice** mode but without the control secondary effects found in the **realistic** mode. Variations in aerodynamic efficiency due to forward speed, air density, aircraft weight, profile and induced drag and other effects are included to give a closer representation of reality. A description of the flight controls follows below.

Realistic mode

Without high-tech fly-by-wire systems, helicopter controls are highly interactive. Movement of any single control will usually require adjustment of another control in order to compensate for undemanded movements. For example, raising the collective lever has the primary effect of increasing lift and causing the helicopter to climb. However, it simultaneously increases rotor torque and the net result is that the fuselage will yaw. The pilot must apply tail rotor input in order to counteract the undemanded yaw. The effects of aerodynamic fluctuations are also included in realistic mode, giving rise to the need for small control corrections, particularly in the hover. You must have at least one joystick in order to use the realistic mode. We advise that you use two joysticks (one cyclic and the other collective) plus a set of rudder pedals.

Other realistic effects: vortex ring, retreating blade stall, ground resonance, and dynamic rollover.

Controls

As in the real Hind, you have three primary flight controls:

Cyclic control (stick) - used to pitch and roll the helicopter. In reality, this control is the pilot's joystick. In Hind, the cyclic control is on the cursor keys or joystick 1. Movement of the cyclic control will tilt the main rotor disc in the direction of the control movement. The effect is achieved by "cyclically" changing the angle of attack of each main rotor blade. For example, to tilt the rotor disc forwards, the angle of attack for each blade is increased as it passes over the tail of the helicopter and decreased as it passes over the nose of the helicopter. The changes in lift result in the helicopter pitching nose down.

At the hover, the cyclic control is used to initiate movement in the desired direction e.g. push forwards gently on the joystick to begin moving forwards. Move the control sideways or rearwards to move accordingly. At higher forward speeds, fore/aft cyclic control puts the helicopter into a dive or zoom climb. Sideways cyclic control is used to roll the helicopter into a turn.

Collective control (lever) - used to control rate of climb and descent and forward speed. In reality, this control is a lever on the left side of the pilot. In Hind, collective control is on keys Q and A or a throttle stick/throttle wheel. Raising the collective lever will "collectively" increase the angle of attack on all five main rotor blades by the same amount and increase the overall lift. Lowering the collective lever has the effect of decreasing the overall lift.

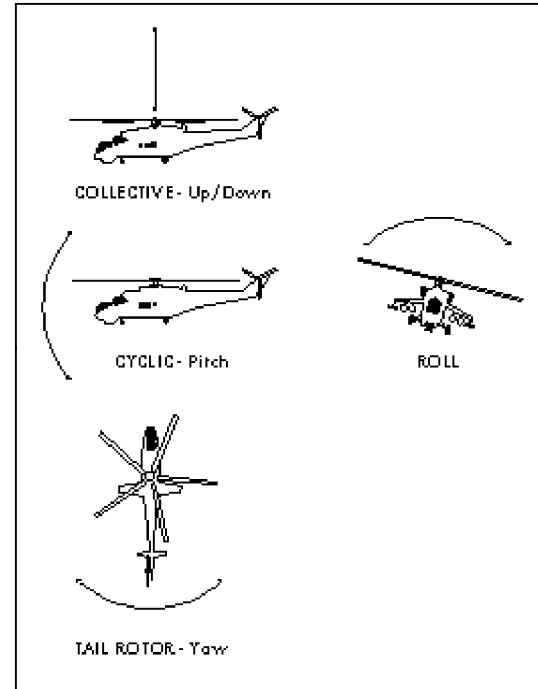

Figure 7.0





In the hover, the collective lever controls vertical ascent or descent rate. Forward speed is sustained by tilting the main rotor disc forwards in order to provide forward thrust. To sustain high forward speeds, the collective lever must be raised significantly in order to generate the extra thrust required to counteract aerodynamic drag.

The power demanded from the engines by the main rotor blades is measured as “torque” and pilots usually refer to a “percentage torque” setting rather than collective lever position.

Tail rotor control - used to yaw the helicopter about its vertical axis (e.g. turning on the spot when hovering). In reality, the pilot uses his “rudder” pedals to vary the pitch of the tail rotor blades. In Hind, tail rotor control is on keys Z and X , i and d , joystick 2 or rudder pedals.

Brakes - press B to apply the wheel brakes.

Undercarriage - the Hind is fitted with a three wheel configuration: two main undercarriage wheels plus a twin nosewheels. Press key U to retract or extend the undercarriage.

Time compression - if you wish to accelerate time, press T to cycle through several levels of time compression or S and T for maximum time compression. Press c and T together (or q) to cancel time compression. N.B. Helicopter control can be difficult at high time compression.

Joystick - press keys c and J together to switch between keyboard and joystick operation. Centralise your joystick and press a and J to recalibrate your joystick in flight. Further information regarding joystick operation can be found in the Installation Guide.

Manoeuvres

Vertical take-off to the hover

Raise the collective lever slowly until the helicopter lifts off. The torque setting at the point of lift off will increase with aircraft weight, but will typically be between 70% to 80%. If you are flying the **realistic** mode, the helicopter will begin to yaw to the left as you become airborne and you will need to apply a small amount of right tail rotor control to stop the yaw rate. The rate of climb will depend upon the torque setting. If you demand over 100% torque, you will hear the overtorque warning. As you approach your desired hover height, lower the collective lever slowly until the helicopter stops climbing. Apply a small amount of left tail rotor to stop any yaw to the right.

Hovering

This refers to flying the helicopter stationary at a fixed height above the ground, with a steady heading. In realistic mode it will be necessary to make small cyclic control inputs in order to hold the helicopter stationary. At heights up to approximately 15 metres the effects of **ground cushion** will be experienced. This has the effect of decreasing the torque setting required to hover. It can best be demonstrated by lowering the collectively lever slightly when hovering at over 30 metres. As the helicopter descends slowly, you should see the rate of descent reduce as you approach the ground. You may have to lower the collective lever further in order to touchdown.

Hovering turn

Turns in the hover are executed with the tail rotor control. When using keyboard control, the rate of yaw is dependant upon how long the control is applied. When using joystick or rudder pedals, the rate of yaw increases with control deflection. In realistic mode, the amount of tail rotor control required for a given yaw rate will depend upon wind direction. Cyclic inputs



will also be required to correct for drift. For example, let's assume that you wish to turn to the right and your helicopter begins facing into wind. The manoeuvre begins with the application of more right rudder to initiate the turn. As you approach the 90 degree position, the amount of tail rotor required will increase due to the tendency of the helicopter to weather-vane back into wind. Left cyclic is required to counteract drift. Continuing to the 180 degree position, tail rotor input will decrease slightly and rearward cyclic input becomes necessary. Turning to the 270 degree position, even less tail rotor input is required due to weather-vaning, and right cyclic input is applied. Completing the turn to 360 degrees requires slight increase of tail rotor to maintain the yaw rate, and forward cyclic control.

Transition from the hover to forward flight

To accelerate forwards, it is necessary to pitch the helicopter nose down. In so doing, lift from the main rotor blades provides the force necessary to accelerate the aircraft. However, the action of pitching down reduces the vertical component of lift and unless the collective lever is raised to compensate, the helicopter will begin to sink. In the **realistic** mode, the increase in torque will require a small tail rotor input to stop the helicopter from yawing. So to summarise the process: push forward gently on the cyclic control, pull up on the collective lever to counteract any descent rate and apply a touch of right tail rotor to counteract any yaw rate. With practice, the maximum level acceleration can be achieved by pulling 100% torque and pitching nose down to an extent where the helicopter does not descend or climb. Raise the nose of the helicopter as you approach your desired forward speed. In the realistic mode the neutral cyclic control position will move forward with increasing speed. Remember to raise the landing gear.

Forward flight

Aerodynamic drag increases approximately with the square of forward speed. As the forward thrust is generated by tilting the main rotor disc forwards,

you may expect the collective setting required to increase with forward speed. This is not the case however. The forward motion of the helicopter has the effect of increasing the lift from the rotor disc, resulting in less collective being needed as speed increases. This effect, known as translational lift, continues up to about 135 kph. Thereafter, the aerodynamic drag increases rapidly, requiring an increase in collective setting for further increases in speed.

Turning in forward flight

Turns are executed by banking left or right. Increase the collective setting during the turn in order to avoid sinking, and apply small tail rotor inputs to compensate for changes in torque. Avoid excessively large roll angles. Control effectiveness reduces as bank angle increases and this can lead to a dangerous loss of control at low altitude.

Slowing down to the hover (flare)

The most effective way to slow down is the flare manoeuvre. Pull back gently on the cyclic control to raise the nose of the helicopter, simultaneously lowering the collective lever in order to avoid a zoom climb. Left tail rotor input will also be required if you are flying the realistic mode. As the speed decays, lower the nose of the helicopter, adjusting collective lever to allow for the loss of translational lift. Apply necessary tail rotor inputs to maintain heading.

Landing

Normally executed from the hover. After extending the landing gear, carefully lower your collective lever, monitoring your rate of descent. Adjust your position over the ground, if necessary, using gentle cyclic inputs prior to touchdown. Be prepared for the effects of ground cushion. Your descent rate at touchdown should be less than 2 metres per second. Damage will result if you land whilst flying sideways or rearwards. Lower the collective lever to minimum after touchdown.



Taxiing

The Hind may be taxied and steered on the ground. Firstly, raise the collective control (key Q) to approximately 40% torque. This is insufficient to lift the Hind off the ground but enough to initiate forward movement by pushing on the cyclic control (joystick 1). Steer the Hind with the tail rotor controls (e.g. keys Z and X). Do not move the cyclic control sideways or you will tilt the helicopter onto one wheel and ultimately onto its side with catastrophic results.

By varying the torque setting with the collective control (up to a maximum of approximately 50%) it is possible to increase your ground speed but care must be taken not to become airborne accidentally. If this happens and you are still pushing on the cyclic control, the Hind will lift off and nose dive into the ground. Be sure to release the cyclic control before increasing the torque setting.

To slow down, simply centralise the cyclic control. You may decelerate quicker by pulling back on the cyclic control, tilting the main rotor disc rearwards. It is not possible to taxi sideways. If you wish to move a short distance sideways, take-off to the hover and push gently sideways on the cyclic control, return to the hover and land. This technique is called hover taxiing.

Rolling take-off

This technique might be used when the helicopter is near to its maximum take-off weight. The manoeuvre is started by raising the collective lever and pushing forward gently on the cyclic control. As the helicopter accelerates along the ground the effects of translational lift will increase to the point where the helicopter becomes airborne. Do not push the cyclic control too far forward or you may end up nose diving into the ground.

Torque turns

Executed frequently at airshows, this manoeuvre involves pulling up into a steep climb, yawing through 180 degrees as the speed bleeds off to zero, and pulling out of the steep dive as the helicopter accelerates towards the ground.

Start by making a mental note of your heading. Begin the manoeuvre by pulling up into a steep climb, simultaneously lowering the collective lever and applying left tail rotor if necessary. As your speed drops to below 30 kph or so, apply full right tail rotor to yaw the helicopter round into a steep dive. Centralise the tail rotor control just before you have completed the 180 degree turn or else you will overshoot. As your speed builds up in the dive, pull back on the cyclic control and raise the collective lever, applying right tail rotor if necessary to counteract unwanted yaw rate. You should now be flying on a reciprocal heading, i.e. your original heading plus 180 degrees. Practise the manoeuvre in both directions, left and right, until you can turn precisely through 180 degrees. This manoeuvre is particularly useful in combat when you may wish to reverse your direction of flight quickly.

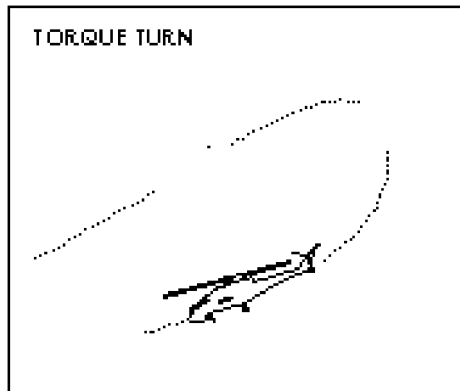

Figure 7.1

Emergency procedures

Autorotation

This is the helicopter's equivalent to gliding in a fixed-wing aircraft. Contrary to what you might expect, helicopters do not drop out of the sky after total loss of engine power. Providing that the pilot responds quickly, it is possible to fly, manoeuvre and land safely - with practice!

If you suffer engine failure, perhaps due to battle damage or running out of fuel, there will be a sudden yaw to the right and a decrease in engine and rotor rpm. You will need to begin autorotation by immediately lowering the



collective lever to its minimum. Failure to do this will result in the main rotor blades slowing down rapidly, followed by catastrophic loss of control. With the correct procedure, the resulting descent rate will provide sufficient “windmill” effect to maintain the rotor blades at or near 100% rpm.

The Hind’s ideal autorotation speed is approximately 120 kph, giving a descent rate in the region of 12 metres per second. If necessary, use your cyclic control to adjust your speed accordingly. Your next task is to decide where to land. Having chosen your landing site, manoeuvre until you are on the approach, decreasing your forward speed gently as you approach the landing point. As you descend through 30 metres, reduce your rate of descent by carefully raising the collective lever. This will cause a slow bleed off of rotor speed as you make your final adjustments for touchdown. It is not necessary to hover prior to landing. In fact, no flare rolling touchdown is easier. Just keep the forward speed below 50 kph and the attitude of the helicopter level as you touchdown. A common error is to either raise the collective lever too early, resulting in a hover too high off the ground with the rotor blades slowing down rapidly, or to raise the collective lever too late, both cases resulting in a heavy (or catastrophic) landing. There is a training mission designed for autorotation - practice makes perfect!

Vortex ring (realistic mode only)

This dangerous condition occurs when the helicopter is descending vertically at a high rate of descent, with power on. The helicopter is effectively descending in its own downwash, incapable of generating any rotor thrust. If left unchecked, the rate of descent can exceed 1000 metres per minute, with total loss of control.

If you are descending rapidly at very low forward speed and unable to control your rate of descent, you are in a vortex ring. Given sufficient altitude, your only escape is to build up forward speed by pushing forward on the cyclic control and diving out of the situation. As your speed increases, level out and check your rate of descent with the collective lever.

Retreating blade stall (realistic mode only)

This phenomenon is experienced typically at very high forward speed, high gross weight, high altitude, or in steep turns. The symptoms are simultaneous loss of roll control, vibration and pitching up. The effect is caused by the fact that at high aircraft speeds, the retreating blade has a relatively low airspeed and a high angle of attack. The condition is corrected by lowering the collective lever, slowing down and less aggressive manoeuvring.

Ground resonance (realistic mode only)

This phenomenon is associated with fully articulated rotor systems and occurs when the helicopter touches down heavily on one wheel. The resultant shock is transmitted to the main rotor system, causing a resonant vibration that amplifies to the point of destroying the helicopter. Corrective action must be immediate, either by lifting the helicopter to the hover or by switching off the engines.

Dynamic rollover (realistic mode only)

This is where the helicopter tips onto its side when on the ground. The phenomenon is normally associated with sloping ground, but it can also occur on level ground if the main rotor disc is tilted downwind by sideways cyclic stick movement. It is more likely to happen if the helicopter has a high centre of gravity, as does the Hind.

Engine failure

It is possible to fly the Hind on one engine but only in certain conditions. It is not possible to hover on one engine, so in the event of engine failure in the hover it is advisable to pull 100% torque on the remaining engine and attempt to gain forward speed in order to generate translational lift. It should then be possible to execute a rolling touchdown.



8. WEAPONS

Summary

The Hind is capable of carrying a wide range of weapons. It is important to understand the purpose of each weapon type and how it is used. Prior to take-off you may view and change your weapon load during the mission briefing (see chapter 4). The weapons are classified into two groups:

Air-to-ground weapons - for use against ground targets

- 9M114 Shturm (AT-6 'Spiral') air-to-ground missile
- S5 57mm rockets
- S8 80mm rockets
- FAB250 & FAB500 general purpose bomb
- OFAB500 blast fragmentation bomb
- FAE-500 fuel air bomb
- KMGU-2 area denial mine dispenser
- Yak-B four-barrelled 12.7mm turret-mounted machine gun
- UBK-23/250 cannon pod

Air-to-air weapons - for use against other aircraft

- R60 (AA-8 'Aphid') missile
- Yak-B four-barrelled 12.7mm turret-mounted machine gun
- UBK-23/250 cannon pod

Press *E* to arm and select weapons. Press *C* and *E* to make weapons "safe". Use *E* to cycle through your available weapons. Use *Z* to fire. Weapons may not be fired when you are on the ground.



Silicon Weapon Systems Operator (WSO)

Target selection and weapon aiming is automatic if you use the Silicon WSO feature (key *S* to toggle on/off). You may instruct the WSO to track targets in the pilot's line of sight by pressing *T* for target tracking. If the WSO is active, pressing *T* will override his choice of target. Press *B* to instruct the WSO to rescan for a target other than his first selection.

Air-to-ground weapons

9M114 Shturm (AT-6 'Spiral' air-to-ground missile)

The 9M114 'Spiral' is a tube-launched High Explosive Anti-Tank (HEAT) missile with an effective range from 500 metres to 5000 metres and a maximum speed of Mach 1.5. It uses a radio-command guidance system with terminal laser guidance from the launch aircraft or ground infantry. The 9M114 is used typically against armoured targets such as tanks and other armoured vehicles. Two missiles may be carried per outer pylon, plus two on each wing tip, giving a maximum total of eight.

To use:

1. Select the 9M114 by repeatedly pressing *E* until the weapon name appears on the HUD.
2. Select the WSO cockpit (*U*) if you wish to use Helmet Mounted Sight, FLIR, LLLTV, or Turret Optics. Alternatively, you may select the "Silicon WSO" (key *S*) and remain in the pilot's cockpit.
3. Position the aiming reticle (or Targeting Circle) over the target. To do this, the WSO uses *a* and cursor keys or *a* and joystick. This happens automatically if you use the Silicon WSO.
4. Select "track target" by pressing *T*. This happens automatically if you use the Silicon WSO.
5. Manoeuvre the helicopter to bring the target within the laser designator's field of view (approximates to the width of the pilot's HUD). Laser



designation happens automatically and is confirmed by the appearance of cross-hairs on the aiming reticle (or Targeting Circle) and range information appears to the left of the display.

6. Release the weapon by pressing Z when the target is within range. A countdown timer in the lower right corner of the HUD shows time to missile impact.

As soon as the missile is clear of the aircraft it will begin to manoeuvre, taking its guidance from target tracking by the WSO. However, if the target is not ahead of the aircraft or the target range is too short, the missile may not have sufficient time to manoeuvre in order to hit the target.

Greatest accuracy is achieved when the target is being illuminated by the laser designator. However, if the target is out of the field of view of the laser designator, or the laser is inoperative due to battle damage or fog, then accuracy of the missile will decrease and there will be no target range information.

Rockets and unguided bombs

All rockets and bombs carried by the Hind may be released manually, or released under computer control, as follows:

Manual weapon release:

1. Select the weapon by repeatedly pressing E until the weapon name appears on the HUD.
2. Select the WSO cockpit (U) if you wish to use Helmet Mounted Sight, FLIR, LLLTV, or Turret Optics. You cannot use the WSO for manual weapon release.
3. Manoeuvre your helicopter to place the bomb CCIP or the rocket boresight over the target.
4. Press Z to release the weapon.

Note: as you approach the target the CCIP will eventually fall below the field of view of the pilot's HUD or the WSO's helmet mounted display. In this situation you will either have to dive towards the target or select computer-controlled weapon release.

Computer-controlled weapon release:

1. Select the weapon by repeatedly pressing *E* until the weapon name appears on the HUD.
2. Select the WSO cockpit (*U*) if you wish to use Helmet Mounted Sight, FLIR, LLLTV, or Turret Optics.
3. Select computer-controlled weapon release by pressing *S* to activate the Silicon WSO.
4. For rockets, manoeuvre your helicopter to place the boresight over the aiming reticle. For bombs, the CCIP is replaced by a small bomb-aiming reticle to indicate lateral displacement of the target. Manoeuvre your helicopter in order to place the bomb-aiming reticle over the HUD datum.
5. A countdown timer in the lower right of the display shows the time to weapon release. Press and hold down *Z* prior to the countdown timer reaching zero. The weapon will be released automatically when the countdown timer reaches zero.

S5 57mm rocket

The S5 is a 57mm folding fin rocket, carried thirty two per pod, with an estimated range of 5000 metres. The B8V20 pods are carried on the inner pylons, giving a total capacity of sixty four rockets. The rockets are unguided, making it necessary to line up with the target prior to launching the weapon. The S5 is used against lightly-armoured targets.

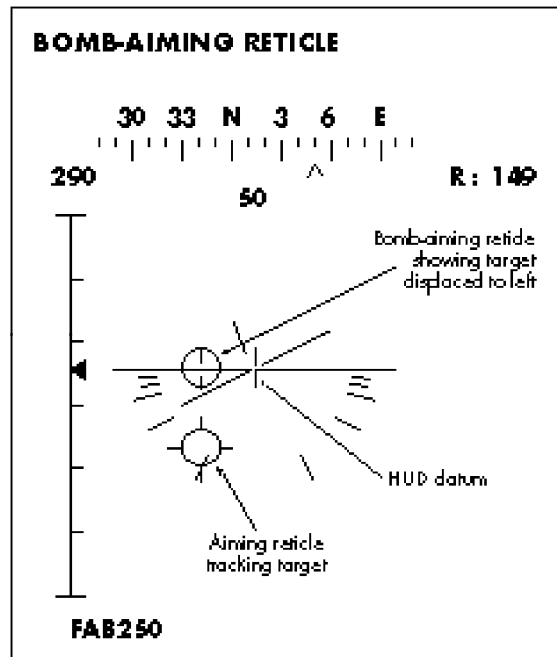

Figure 8.0



S8 80mm rocket

The S8 is an 80mm folding fin rocket, carried 20 per pod, with an estimated range of 1200 metres. The UB-32A-24 pods may be fitted to all four pylons, giving a total capacity of eighty rockets. The rockets are unguided, making it necessary to line up with the target prior to launching the weapon. The S8 is used against armoured targets such as tanks and other armoured vehicles.

FAB250 and FAB500 free fall bombs

These equate to the West's general purpose bombs. Available in several sizes, we have included the 250 kg and the 500 kg versions. Up to four FAB250 may be carried (1 per pylon) or two FAB500 (1 per inner pylon).

OFAB250 blast fragmentation bomb

This is a variation of the FAB250 that bursts into a cloud of small fragments prior to hitting the ground. The weapon is used against personnel and lightly armoured vehicles. Up to four may be carried, one per pylon.

FAE-500 fuel air bomb

This is a variation of the FAB500. This awesome weapon is detonated above ground with an incredible blast effect, spreading a highly explosive mixture of petrochemicals. It is used for anti-personnel and light industrial targets. Two may be carried, one per inner pylon. Due to the incredible blast effect produced by this weapon, the lowest altitude for safe release is 300 metres. Release below this will result in damage and possibly death.

KMGU-2 area denial mine dispenser

This weapon contains four compartments, each carrying 36 anti-personnel mines. The submunitions are dispensed one compartment at a time while

flying straight and level at low altitude (50 metres to 150 metres) and at high speed. The submunitions disperse and remain live on the ground as a means of area denial.

Yak-B 12.7mm turret-mounted machine gun

This is a four-barrelled machine gun fitted in a USPU-24 remotely-controlled turret capable of traversing 60 degrees left and right, sixty degrees down and twenty degrees up. The gun is believed to be capable of at least 4000 rounds per minute, with a maximum range of 1500 metres. A full ammunition load is 1470 rounds of either armour-piercing or incendiary 12.7mm shells. The gun is used typically for fire suppression, lightly armoured vehicles, parked aircraft or other soft targets.

To use turret aiming:

1. Select the gun by repeatedly pressing *E* until the weapon name appears on the HUD.
2. Select the WSO cockpit (*u* or *3*) if you wish to use Helmet Mounted Sight or the Turret Optics. Alternatively, you may select the “Silicon WSO” (key *S*) and remain in the pilot’s cockpit.
3. Position the aiming reticle (or Targeting Circle) over the target. To do this, the WSO uses *a* and cursor keys or *a* and joystick. This happens automatically if you use the Silicon WSO.
4. Select “track target” by pressing *T*. This happens automatically if you use the Silicon WSO. If you do not wish to track targets, you may omit this step and simply aim the machine gun manually.

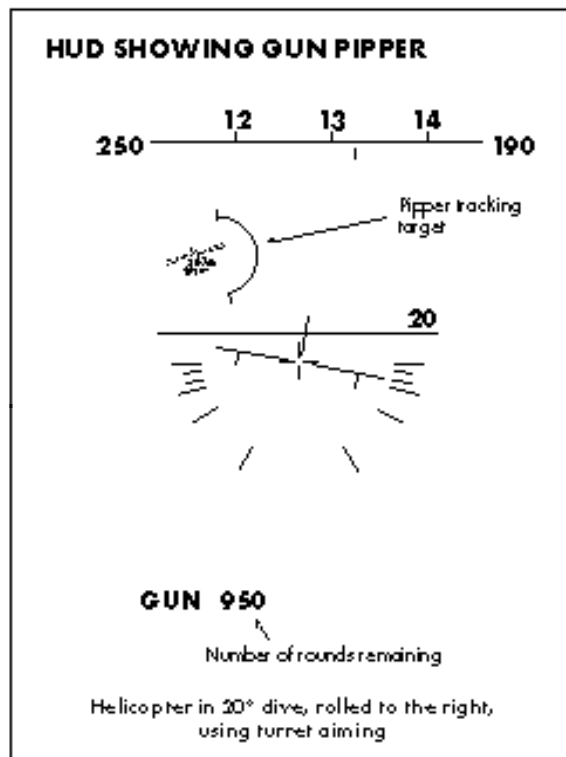

Figure 8.1



5. Using your judgement to estimate target range, you may fire when ready by pressing Z . If you wish to see ranging information, manoeuvre the helicopter to bring the target within the laser designator's field of view (approximates to the width of the pilot's HUD). As the target comes into range, the Aiming Reticle will change to a Gun Pipper that "unwinds" to indicate target range.

UPK-23/250 cannon pod

Each pod contains a twin-barrelled GSh-23L 23mm cannon and 250 rounds of ammunition. The pods are mounted on the inner pylons only. The gun is estimated to be twice as powerful as the turret-mounted machine gun but has the disadvantage of having to turn the whole helicopter in order to aim the weapon. The pods are fixed to fire straight ahead towards the boresight. The gun may be used against lightly armoured vehicles, strongpoints and air-to-air combat.

To use:

1. Select the cannon by repeatedly pressing E until the weapon name appears on the HUD.
2. Manoeuvre the helicopter to bring the target within the laser designator's field of view (approximates to the width of the pilot's HUD). Laser designation happens automatically and is confirmed by the appearance of cross-hairs on the Aiming Reticle.
3. Continue to manoeuvre so as to place the aiming reticle over the boresight (see figure 8.2)
4. As the target comes into range, the Aiming Reticle will change to a Gun Pipper that "unwinds" to indicate target range. With the gun pipper overlaying the boresight marker, fire the weapon by pressing Z .

Air-to-air weapons

R60 (AA-8 'Aphid') missile

One of the smallest guided missiles ever built, the R60 has an estimated range of between 500 metres and 5500 metres and a maximum speed of approximately Mach 2.5. It is guided by an infra-red heat seeker in the nose of the missile, capable of tracking targets within its +/- 20 degrees field of view. Its propulsion system is probably of the boost-coast type whereby the rocket motor quickly accelerates the weapon to its maximum speed and then the weapon coasts for the remainder of its flight. Two R60 missiles may be carried on each outer pylon, giving a total capacity of four.

To use:

1. Select the R60 by repeatedly pressing *E* until the weapon name appears on the HUD.
2. Select the WSO cockpit (*u*) if you wish to use the Helmet Mounted Sight. Alternatively, you may select the "Silicon WSO" (key *S*) and remain in the pilot's cockpit.
3. Position the aiming reticle (or Targeting Circle) over the target. To do this, the WSO uses *a* and cursor keys or *a* and joystick. This happens automatically if you use the Silicon WSO.
4. Select "track target" by pressing *T* . This happens automatically if you use the Silicon WSO.
5. Manoeuvre the helicopter in order to bring the target within the missile's field of view (+/- 20 degrees of the helicopter's nose). The missile will confirm lock-on by superimposing cross-hairs on the Targeting Circle. Laser designation occurs automatically when the target is within the width of the pilot's HUD and range information appears to the left of the display.
6. Release the weapon by pressing *z* when the target is within range.

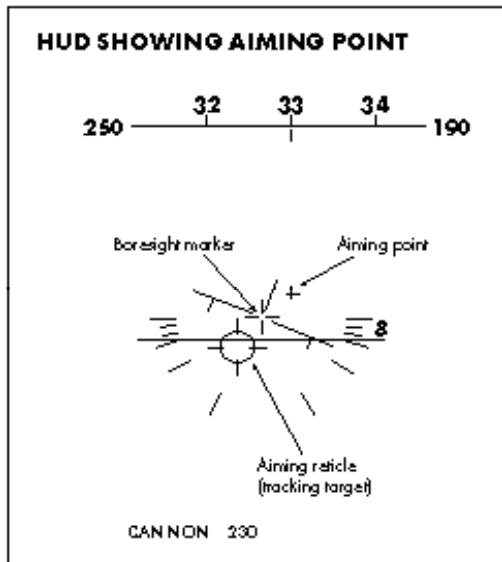

Figure 8.2

Yak-B 12.7mm turret-mounted machine gun

Operation is similar to when attacking ground targets, but with one important difference: the target will be moving. The weapon aiming system automatically allows for this and aims the gun ahead of the target.

To use turret aiming:

1. Select the gun by repeatedly pressing *E* until the weapon name appears on the HUD.
2. Select the WSO cockpit (*u*) if you wish to use Helmet Mounted Sight or the Turret Optics. Alternatively, you may select the "Silicon WSO" (key *S*) and remain in the pilot's cockpit.
3. Position the aiming reticle (or Targeting Circle) over the target. To do this, the WSO uses *a* and cursor keys or *a* and joystick. This happens automatically if you use the Silicon WSO.
4. Select "track target" by pressing *T* . This happens automatically if you use the Silicon WSO. If you do not select "track target" then the aiming system will be unable to allow for target movement.
5. Using your judgement to estimate target range, you may fire when ready by pressing *z* . If you wish to see ranging information, manoeuvre the helicopter to bring the target within the laser designator's field of view (approximates to the width of the pilot's HUD). As the target comes into range, the Aiming Reticle will change to a Gun Pimper that "unwinds" to indicate target range.

UPK-23/250 cannon pod

The cannon may only be used in boresight mode as the orientation of the cannon pods is fixed. The sighting system automatically detects target movement and adds an **Aiming Point** to the display (see figure 8.2). This is the estimated position of the target at the time that the machine gun shells reach the range of the target. The Aiming Point will be displaced from the target in order to create the required amount of “lead”.

To use:

1. Select the cannon by repeatedly pressing *E* until the weapon name appears on the HUD.
2. Select the WSO cockpit (*u*) if you wish to use Helmet Mounted Sight or the Turret Optics. Alternatively, you may select the “Silicon WSO” (key *S*) and remain in the pilot’s cockpit.
3. Position the aiming reticle (or Targeting Circle) over the target. To do this, the WSO uses *a* and cursor keys or *a* and joystick. This happens automatically if you use the Silicon WSO.
4. Select “track target” by pressing *T*. This happens automatically if you use the Silicon WSO. If you do not select “track target” then the aiming system will be unable to allow for target movement.
5. Manoeuvre the helicopter to bring the target within the laser designator’s field of view (approximates to the width of the pilot’s HUD). Laser designation happens automatically and is confirmed by the appearance of cross-hairs on the aiming reticle.
6. Continue to manoeuvre so as to place the **boresight marker** over the **aiming point** (see figure 8.2)
7. As the target comes into range, the aiming reticle will change to a gun piper that “unwinds” to indicate target range. With the **boresight marker** overlaying the **aiming point**, fire the weapon by pressing

z



Delivery Techniques

We suggest that you practise using the various weapons in the Training missions. Here you can select infinite weapons, turn crash detection off and there is no threat of enemy defences. By perfecting your weapon delivery technique, your chances of surviving and succeeding in combat are greatly improved.

Begin with the Silicon WSO switched on (press key S to toggle on/off). He will locate targets for you, verbally confirm target type, aim the weapon, and track targets. When you are familiar with the effect of each weapon, turn the Silicon WSO off and perform his tasks yourself.

Unguided bombs

The two common techniques for the delivery of unguided bombs are the **laydown attack** and the **dive attack**. Laydown bombing is where the aircraft flies straight and level at high speed over the target and releases its bombs. Climbing prior to the attack run and then diving towards the target usually results in higher accuracy, but at the risk of increased exposure to enemy air defences during the initial climb. There will also be less risk of the CCIP disappearing below the aircraft when dive bombing.

Care must be taken not to fly through the debris hemisphere of the exploding weapon or else catastrophic consequences may occur. As a rule of thumb, do not fly lower than 150 metres when using 250kg bombs, and 300 metres for 500kg bombs. Note: bombs are always released in pairs. If you have four bombs loaded, you can only attack two targets, or the same target twice.

Use the computer-controlled weapon release whenever possible. Doing so means that you only need to line up with the target in azimuth.

It is also possible to loft unguided bombs, sometimes referred to as “toss bombing”. (see figure 8.3) The advantage of this technique is that the attacking aircraft can turn away from the target area as soon as the bombs are released and avoid flying over the target defences. The technique is not often employed by helicopters because of the typically low airspeeds when compared to fixed wing bombers. Nevertheless, you may wish to experiment with this technique. Note: this technique should not be used for the KMGU-2 area denial mine dispenser. The weapon dispenser is designed for high speed straight and level delivery only. (Described below)

The technique begins with a continuous pull up into a climb. The bomb is released with an upward velocity and follows a parabolic trajectory to the target. Release the weapon before your airspeed has decayed significantly, simultaneously keeping the CCIP on the target. The manoeuvre may be completed with a hard steep turn or a torque turn through 180 degrees.

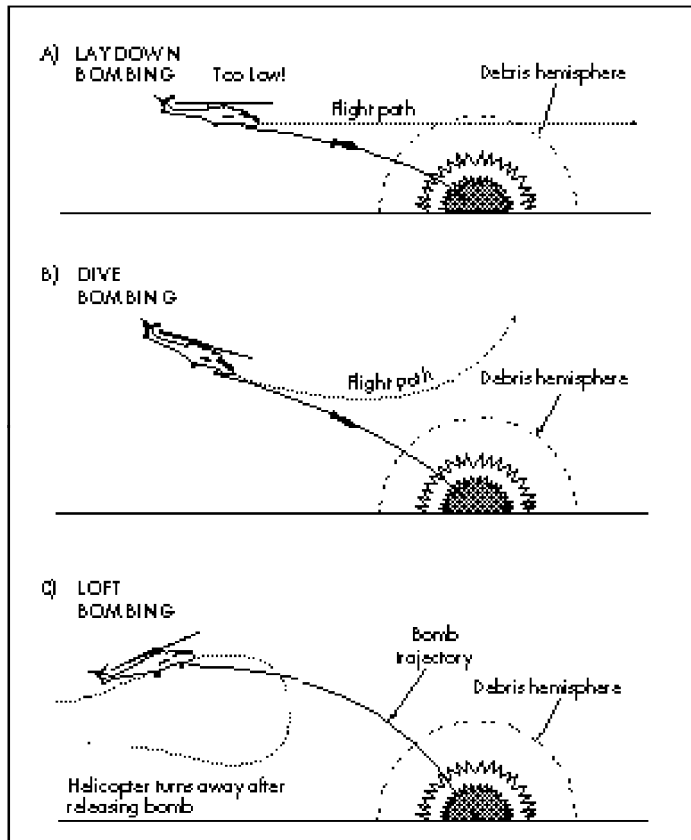

Figure 8.3

Rockets

Rockets may be fired from the hover or, more typically, with forward speed. The natural nose down attitude adopted with increasing forward speed assists in aiming the rockets. The first salvo is usually fired with computer-



controlled weapon release, meaning that the pilot need only make azimuth adjustments with the tail rotor in order to line up with the target.

Attack convoys or trains along their length, not from the side. Use the road or rail track as a visual aid to line up for the attack. Approach from the rear to minimise relative speed and maximise your aiming time. Don't spend too long setting up the ideal attack or your target may turn a corner!

Mine laying using the KMGU-2 area denial mine dispenser

The "laydown attack" technique must be used for correct delivery of this weapon. The optimum dispersal pattern of the mines will be achieved by flying straight and level over the target area at 200 kph and 50 to 150 metres altitude.

Air-to-air missiles

The R60 'Aphid' is a small infra-red guided missile with a solid-fuel rocket motor. It accelerates to its maximum speed within a few seconds, at which point the solid-fuel is exhausted and the weapon spends the remainder of its flight coasting and decelerating due to aerodynamic drag and the effects of gravity. The effective range of the missile will depend upon the altitude at which it is launched and the speed and aspect of the target.

Missile ranges are significantly greater at higher altitude due to the lower air density and it is these figures that are normally quoted in the manufacturer's literature. The typical combat arena for helicopters is much closer to sea level, where missile performance can be severely limited. Expect the effective range to reduce to under 3000 metres at sea level.

The speed and aspect of the target also have an important impact upon missile effectiveness. If the target is travelling towards you, the range of the missile will be increased by the distance travelled by the target during the flight of the missile. Conversely, if the target is travelling away from you, the



missile may never even catch the target. Firing at a target crossing your path will mean that the missile has to manoeuvre continuously in order to intercept the target. This can create significant aerodynamic “manoeuvre” drag, slowing down the missile during its coasting phase and reducing its effective range. Remember that the enemy will be employing all of these tactics, plus decoy chaff and flares, in order to escape your attack.

Countermeasures

IR jammer

The Hind is fitted with the L-166V-1AE Ispanka pulse-type dorsal IR jammer. The unit transmits infra-red pulses of a magnitude greater than the IR signature of the Hind itself in order to confuse infra-red-guided missiles. Operation is fully automatic.

Chaff and flares

The Hind is fitted with two ASO-2V chaff/flare launchers arranged as two triple clusters with a total of 192 rounds. Flares are used as decoys to confuse incoming infra-red guided missiles. Chaff consists of radar-reflecting strips dispensed in cloud form to confuse radar-tracking equipment as used by anti-aircraft artillery and radar-guided missiles. Chaff and flares are dispensed at irregular intervals by arming the launcher. Press key **C** for chaff and key **F** for flares. Press **C** or **F** again to switch off the launcher.

The use of chaff or flares does not guarantee immunity from an incoming missile or the threat of anti-aircraft artillery. Your chances of evading the threat are improved considerably if you manoeuvre aggressively immediately after using chaff or flares. The effectiveness of decoys has limited duration and your objective must be to have turned out of the threat's field of view before the decoy ceases to be effective.



9. MULTIPLAYER GAMES

Two player games

Select this option if you wish to link two computers via modem, direct cable link or network, and fly with a friend. You will need a copy of Hind or Apache Longbow on both computers. The two player games are accessed as follows:

1. At the Main screen select Flight
2. At the Flight screen select Two Player

N.B. two player games are not saved to the pilot's log.

Two Player options

- Combat** - a simple head-to-head dual. Combat will always take place in Korea because this is the common scenario in Hind and Apache Longbow. Scores will be displayed at the debriefing between flights. Either player may select weather conditions, time of day and crash detection on or off. The program will automatically detect the type of aircraft that your opponent is flying. One user must select Player One and the other Player Two.
- Single missions** - in this option you will either (a) both be flying Hind helicopters as leader / wingman on single missions in any combat area or (b) flying Hind versus Apache, with each player flying as aggressor or defender in the Korea combat zone. One user must select Player One and the other Player Two. Player One will select the mission. Both players will then be briefed prior to take-off.
- Pilot / WSO** - in this option you will both fly in the same Hind. One player must select to fly as the Weapon Systems Operator (WSO) and the other player must select to fly as the pilot. You may fly on any of the single missions in any combat area. Pilot picks scenario and mission. Both players will then be briefed prior to take-off.

Set up for two player games

a) Connection via modem

The modem interface supports any Hayes-compatible modem (AT commands) that is capable of at least 2400/2400 baud (V22 bis 2400) but we recommend a V32 modem (or better) with a serial port baud rate of at least 19200. If you run at a baud rate of less than 19200 then the game may slow down.

To use a modem for two player games, proceed as follows:

1. Connect a modem to any serial port (COM 1 to COM 4) and select the port by clicking on the appropriate screen button.
2. If a non-standard port IRQ is used, select the appropriate button.
3. Select a baud rate. We recommend playing at 19200 if you have a 14400 modem, or 38400 if you have a 28800 modem. If your PC uses an 8250 IC we recommend 19200 baud. Selecting very high baud rates may cause data errors and there is no benefit in using higher speeds with current modems.
4. Select your modem type.
5. Click on the Modem button to enable the modem controls. The dialogue box will display "Initialise modem" followed by initialisation messages and OK if successful. If a problem occurs you will see a message e.g. "transmission error" or "no reply, rest modem and retry". Further explanation on fault finding is given below.
6. Click on Game Mode for two player options e.g. Combat Single Missions, Pilot / WSO. Select each player's function - one player must select the left button and the other player the right button.
7. Decide which player will be the "caller". The other player will be the receiver.
8. For the caller to dial a number, click on the "phone no." button, enter the number, (see your modem manual for any special command characters) followed by *E* .

9. Select Tone or Pulse dialling and then click on the Dial button. The dialogue button will say “Dialling number” followed by “Connect nnnnn” if successful, where nnnnn is the baud rate.

Possible errors:

- i) “No dial tone” - check that your modem is connected to the phone line.
- ii) “Busy” - line is engaged.
- iii) “No answer” - receiver not responding.
- iv) “No carrier” - receiver’s phone is answering but his modem is not responding. See below for other error messages.

10. The receiver may use either “auto-answer” or “manual answer”. For auto-answer, click on the auto-answer button and wait for the phone to ring. The dialogue box will say “Awaiting call”, followed by “RING” and “CONNECT nnnnn” when the phone has rung and the connection has been established. Alternatively, if you wish to use manual answer, click on the manual answer button when the phone rings.
11. As soon as communication between the two computers is established, the dialogue box will print “Testing link”, then “Machines linked”, “Menu data sent”, “Received other machines menu data” followed by further instructions.
12. The game will begin at this point if the link is successful. If an error occurs when testing the link, determine the cause of the error and try again by pressing the Start Game button.
13. At the end of the game you will return to the Two Player Set Up screen. If you wish to send a message to your opponent at this point, click on the Message button (which has replaced the Command button) and then type in the required text. Press Start Game to begin again.
14. To abort a call once a connection has been made, click on the “Hangup Modem” button. The dialogue box will confirm this by printing “Hang up phone” followed by OK if successful.

15. The “Command” button is used to send commands to the modem to reconfigure it, check its status, etc. To send a command, click on the button, enter the command and then press *E* . Clicking on the button will abort entry and the command will not be sent. Once the two computers are connected the “Command” button is relabelled “Messages” and is used to send message strings between the two players. To send a message, click on the button, type the message and press *E* .
16. The port number, interrupt, baud rate, modem type and phone type are all saved in the file PREFS.CFG so that the program is already configured when you next use it. The phone book section allows you to save up to six frequently used numbers, entered as follows:
- i) type in the phone number (see 8 above)
 - ii) press the “phone book set” button
 - iii) click on the phone book button where you wish to save the number
 - iv) enter the text string and press *E* . The phone number is now saved on this button.

Fault finding when using a modem

Modem messages are the same as the standard Hayes messages with the following additions:

“Checksum error”	data corruption
“Unexpected reply”	expecting OK but got a different response
“Transmission error”	serial communication problem
“Timeout error”	no response from modem

All errors described below for direct link operation also apply.

Problems

1. If the modem is not responding:
 - i) Check all connections and check that the modem is switched on.
 - ii) The modem may be in “quiet” mode. Try cancelling this mode by sending “ATQ0” command.

2. Communications error when "Testing link":
 - ii) Both users should try to re-establish the link by clicking on the "Start Game" button.
 - iii) Have you selected a baud rate that is compatible with your modem?
 - iv) Try using a lower baud rate i.e.9600
3. Did you dial the wrong number? Select "Hang up" and retry.
4. Have you selected the right COM port? Check to see which port your cable or modem is plugged into.
5. Are you clear about who is the "caller" and who is the "receiver"? If you both try to be "caller" you will get nowhere.
6. If your phone has a "Call waiting" facility, this may disrupt the modem connection during the game. It should be possible to disable this feature temporarily prior to starting your game. Check in your phone handbook.

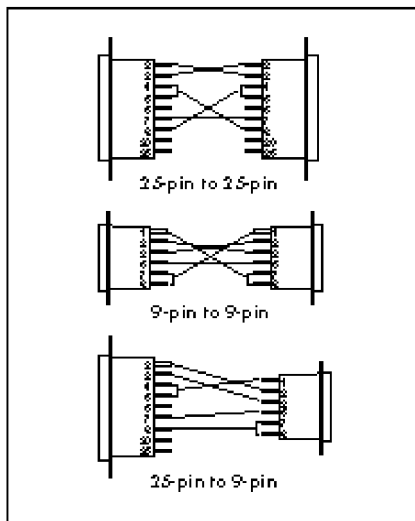

b) Direct link using null modem cable

If you intend to use a direct cable link, a "null modem" cable must be connected into a serial port on each computer. The plugs on the ends of your null modem cable must match the ports of both computers. The ports will either be 9-pin or 25-pin and will probably be male (pins).

If you do not have a null modem cable, you may order one direct from Digital Integration sales on 01276 684959. Check the ports on both computers before ordering your cable. As the diagram shows, there are three possible configurations for your cable.

You do not need a modem in order to use a "null modem" cable. Just plug one end of the cable into a serial port (e.g. COM 1) on one of the computers and plug the other end into a serial port (e.g.

COM 1) on the other computer. The length of cable will limit how far apart you can place the computers, up to a maximum of several hundred feet.

Proceed as follows:

1. Specify the baud rate, interrupt number and serial port that you wish to use. The same baud rate must be used on both computers. If you run at a baud rate of less than 19200 then the game may slow down.
2. Select Game mode e.g. Combat, Single Missions, Pilot / WSO
3. Click on Start Game button.
4. The dialogue box will announce “Testing link”, followed by “Machines linked”, “Menu data sent”, “Received other machines menu data”, followed by further instructions.

Fault finding when using direct link

- i) Are the pin connections correct on your cable? Check the diagram.
- ii) Have you both selected the same baud rate?
- iii) Has each player selected Player 1 or Player 2?

Error messages

“**Timeout**” - one or both computers are not receiving data. The possible causes are:

- i) computers are not connected to each other
- ii) cable connected to the wrong serial port or incorrect serial port selected
- iii) faulty cable
- iv) different baud rates selected
- v) more than 5 seconds had elapsed between both players selecting Start Game.



“Transmission error” - this is caused by data corruption, possible due to an excessively long cable or an electrically “noisy” environment. Try re-routing the cable.

“Checksum error” - see Transmission error

“Error both players must pick combat or pilot/ WSO” - players have selected different game modes. One player must change so that the game mode selected on both machines is the same.

“Error - both Player 1 or both Player 2” - Both players have selected the same option. One player must change.

c) Connection across a network

Two player games may also be played using a network to connect the two computers. Proceed as follows:

1. Select Network on the Two Player screen
2. Select game mode: Combat, Single Missions, Pilot / WSO
3. Both players must select a common channel number that is different from any other players on the network.
4. Click on the Start Game button.

Sending in-flight messages in two player games

A number of predefined messages may be transmitted between players when both flying in a Hind on single missions. The messages will be audible or printed on the message panel below the HUD. Press **C** and key **1** to **O** to send the following messages:



WSO to Pilot

- c - 1 Break left.
- c - 2 Break right.
- c - 3 Break off.
- c - 4 Slow down.
- c - 5 Fly faster.
- c - 6 Turn left.
- c - 7 Turn right.
- c - 8 Straight ahead.
- c - 9 Go around again.
- c - 0 Let's go home.

Pilot to WSO

- c - 1 Target left.
- c - 2 Target right.
- c - 3 Target ahead.
- c - 4 Target behind.
- c - 5 Take defences.
- c - 6 Take gnd targets. (gnd = ground)
- c - 7 Take air targets.
- c - 8 Hold your fire.
- c - 9 Going round again.
- c - 0 Let's go home.

Leader / Wingman

- c - 1 Break left.
- c - 2 Break right.
- c - 3 Break off.
- c - 4 Regroup.
- c - 5 Take defences.
- c - 6 Take gnd targets. (gnd = ground)
- c - 7 Take air targets.
- c - 8 Low on weapons.
- c - 9 Going round again.
- c - 0 I'm going home.



Network Games

Up to sixteen players may compete across an ipx network. Access to the Network games is as follows:

1. At the Main screen select Flight
2. At the Flight screen select Network

N.B. details of network games are not saved to the pilot's log.

There are two network games:

- (a) **Death Match** - a game of survival, either for individuals or teams
- (b) **Capture The Flag** - a game where your objective is to destroy the enemy's headquarters.

Hind will automatically detect if it is connected across the network to **Apache Longbow**. If so, both network games are split into teams of Hinds and Apaches.

Once you reach the Network Setup screen, you will see a list of up to sixteen players. Click on the "Enter Name" button, type in your name (up to eight characters) and press *E*. Your name will be added to the list. Preferences listed on screen should also be set or reset.

Click on Take-off when all players are present on the list. Your start position is set randomly. During the game a player may repair damage or re-arm with weapons by landing. Press *c q* to exit the game. If you are shot down in either game, you will be re-initialised at an appropriate position so that you may continue in the game.



HIND[®]



10. HIND - HISTORY AND DEVELOPMENT

The Mil Mi-24, NATO codename 'Hind', is an assault helicopter capable of carrying troops to the battlefield and supporting them with awesome firepower. This concept differs greatly from Western design philosophies where dedicated helicopter gunships such as the AH-64 Apache are used for battlefield support and helicopters such as the UH60 Blackhawk are used for troop transport.

The design of the Hind can be traced back to the **Mi-8**, NATO codename 'Hip', a medium lift transport helicopter with a number of armed variants in the mid 1960s. Components of the Mi-8 were used to form the basis of the Hind, the first dedicated attack helicopter to be built in the Soviet Union.

The Soviets studied reports on American helicopter operations in Vietnam with considerable interest. Unlike the West, they remained convinced of the benefits of a heavily armed troop carrier. In 1966 the Mil Design Bureau was tasked by the Soviet government to design such a helicopter. The new gunship was to be smaller and more powerful than the Mi-8, with stub wings for weapon attachment and enhanced lift at higher speeds. The first prototype, the **V-24**, was completed in 1969. The flight crew consisted of pilot, gunner and engineer. Up to eight troops could be carried in the central cabin. During flight trials, one aircraft was fitted with a 'fenestron' shrouded tail rotor, similar to the Gazelle, but the design was rejected. The first production aircraft, designated the Mi-24, was delivered to the Soviet Air Force in 1972.

During early production, several significant design changes were incorporated on the **Hind A**. The stub wings were mounted with a pronounced anhedral in order to reduce the effects of downwash from the



main rotor blades when hovering. Plates were fitted to the ends of the stub wings for the purpose of mounting AT-2 Swatter anti-tank missiles. A director pod for the AT-2 missile was fitted under the nose of the helicopter. Later models were fitted with more powerful 2,200 shp Izotov TV-3-117 turboshaft engines. The tail rotor was moved to the port side of the vertical fin and its direction reversed in order to improve yaw control. It is an interesting fact that a modified version of the Mi-24 Hind A, known as the A-10, broke eight world records for helicopter performance during 1975, including speed, climb rate and altitude.

The deployment of two regiments of 45 Hind A's in East Germany during 1974 caused NATO considerable concern. The West had no equivalent of such a heavily armed helicopter. NATO tank crews nicknamed the helicopter the 'bogeyman' due to its fearsome appearance and devastating firepower.

In-service use of the Hind A highlighted several shortcomings. Crews complained of vulnerability to enemy ground fire, cockpit visibility and limitations of the machine gun. The Mil Design Bureau began a major improvement program in 1974, leading to the first appearance of the Mi-24DU (NATO designation **Hind D**) in 1976. Considered by many observers as a completely new helicopter, the Hind D featured a completely redesigned nose section with stepped tandem cockpits for pilot and gunner. Visibility for both crew was improved dramatically. Crew protection included armoured seats and armoured glass windshields. External pods housed low light TV sensors and forward-looking Infra-Red equipment, allowing the Hind D to operate at night and in poor weather conditions. The single gun of the Hind A was replaced by a rotary machine gun capable of firing 4000 rounds per minute, mounted in a turret capable of traversing 60 degrees left and right, twenty five degrees down and fifteen degrees up. The engine air intakes were fitted with dust/debris extractors, although this modification resulted in



some loss of performance. Further enhancements to the Hind D include the addition of infra red suppression units on the engine exhausts in order to decrease vulnerability to IR surface-to-air missiles.

Developments in anti-tank missile technology lead to modifications to the Hind D so that it could carry the new Spiral AT-6 missile. The addition of the new fixed Shturm V guidance antenna and attachment points for the new missiles resulted in the definitive Mi-24V, and a new NATO designation **Hind E**. First test flights took place during 1976 but production was limited until the Spiral missile became fully operational. New avionics included an Infra Red jammer, new communications and navigational equipment, and a passive warning radar unit.

In 1982, NATO learned of yet another variant, the **Hind F**. The turret-mounted gattling gun had been replaced with a twin-barrelled cannon mounted on the starboard side of the nose. Although this weapon offers significantly greater fire power, it has the distinct disadvantage in that the entire aircraft must be manoeuvred in order to aim at a target. This also means that it is no longer possible to engage multiple targets simultaneously with cannon and missiles. It is for this reason that DI chose to base this simulation on the Hind E variant.

Specification Mil Mi-24V 'Hind E'

Main rotor diameter	56 ft 9 in
Tail rotor diameter	12 ft 8 in
Length	55 ft 11 in
Height	18 ft 7 in
Weight, empty	18,519 lbf
Weight, max.	25353 lbf
Payload per wing	1653 lbf
Powerplant	Two Isotov TV3-117 turboshaft engines 2,200 shp each
Armament	One turret-mounted 12.7 mm four-barrelled gattling gun Up to 12 Spiral anti-tank missiles Rocket pods Cannon pods Unguided bombs
Performance	Vmax 335 kph Service ceiling 14,700 ft Range 373 mls Vertical climb rate from hover 500 ft/min.
Crew	3 - pilot, navigator/weapons officer, flight engineer

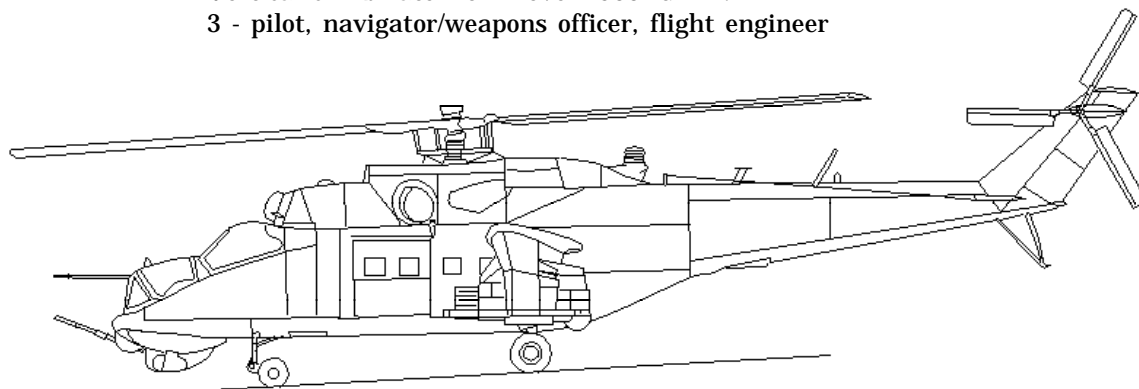
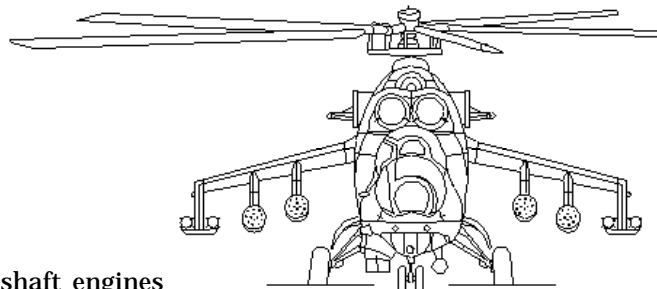

11. VEHICLE INVENTORY

Allies

Helicopters

Mil-24 Hind-E
Mil-17 Hip

Fixed wing aircraft

MiG-29 Fulcrum
MiG-27 Flogger
Su-25 Frogfoot
An-12 Cub-A

Air defence

SA-8 Romb SAM
SA-9 Gaskin SAM
ZSU-23 Shilka AAA

Armoured vehicles

T62 Tank
BMP2 Armoured Personnel
Carrier
BRDM2 Armoured Personnel
Carrier
BRDM2 + Sagger
MT-LBU Armoured Personnel
Carrier
MT-LBUS ECM

Artillery

M37 82mm Mortar
D30 Howitzer
MAZ543 SCUD

Infantry Weapons

7.62mm AK-47 Rifle
12.7mm DSh K-38 Heavy
machine gun
RPG-7 Rocket propelled grenade
SA-7 Anti-aircraft missile

Ships

Romeo submarine
Osa missile boat
Mine layer
Landing Craft
Oil tanker
Cargo ship
Tug
Supply barge

Other

Long track radar
Fuel bowser
Military truck
UAZ469 Light utility vehicle
Train



Vehicle recognition Screen



Enemy - Korea

Helicopters

AH64D Apache Longbow
AH64C Apache
UH60 Blackhawk

Fixed wing aircraft

F15 Eagle
F16 Fighting Falcon
F18 Hornet
A10 Thunderbolt
C130 Hercules

Air defence

Patriot SAM launcher
M163 Vulcan AAA

Armoured vehicles

M1A1 Abrams tank
M113 Armoured Personnel
Carrier

Artillery

M29A1 81mm Mortar
MLRS AFV
M109 howitzer

Infantry Weapons

7.62mm M16 rifle
12.7mm M2 heavymachine gun
M47 Dragon anti-tank guided
weapon
Stinger anti-aircraft missile

Ships

LHA Tarawa assault ship
Perry Class frigate
Oil tanker
Cargo ship
Tug
Supply barge

Other

Giraffe mobile radar
Fuel bowser
Military truck
HMMWV multi-purpose wheeled
vehicle
Train

Enemy - Afghanistan

Mujaheddin

Artillery

M37 82mm Mortar
D30 Howitzer

Infantry Weapons

7.62mm AK-47 Rifle
12.7mm DSh K-38 Heavy
machine gun
RPG-7 Rocket propelled grenade
SA-7 Anti-aircraft missile

Other

Truck



Enemy - Kazakstan

Helicopters

Mil-24 Hind-E
Mil-17 Hip

Fixed wing aircraft

MiG-29 Fulcrum
MiG-27 Flogger
Su-25 Frogfoot
An-12 Cub-A

Air defence

SA-8 Romb SAM
SA-9 Gaskin
ZSU-23 Shilka AAA

Armoured vehicles

T62 Tank
BMP2 Armoured Personnel
Carrier
BRDM2 Armoured Personnel
Carrier
BRDM2 + Sagger
MT-LBU Armoured Personnel
Carrier
MT-LBUS ECM

Artillery

M37 82mm Mortar
D30 Howitzer
MAZ543 SCUD

Infantry Weapons

7.62mm AK-47 Rifle
12.7mm DSh K-38 Heavy
machine gun
RPG-7 Rocket propelled grenade
SA-7 Anti-aircraft missile

Other

Long Track Radar
Fuel Bowser
UAZ469 Light utility vehicle
Military Truck

Enemy - Pakistan

Helicopters

AH1W Supercobra
Mil-17 Hip

Fixed wing aircraft

F16 Fighting Falcon
C130 Hercules

Air defence

35mm Oerlikon GDF SPAAG
Tracked Rapier

Armoured vehicles

T62 Tank
M113 Armoured Personnel
Carrier

Artillery

M29A1 81mm Mortar
M109 howitzer

Infantry Weapons

7.62mm M16 rifle
7.62mm M60 general purpose
machine gun
TOW anti-tank guided weapon
Stinger anti-aircraft missile





12. CREDITS

Hind team

Project manager

Rod Swift

Design team

James Brewster
Laurie Dobson
Todd Gibbs
Simon Hegarty
Kethon Islam
David Marshall
Nick Mascal
Gavin Monahan
Andrew Morgan
Dave Proctor
Scawen Roberts
Aaron Robson
Rod Swift
Nick Webber

Manual

David Marshall

Manual layout,
graphics, & artwork

Wendy Christoforato
Grant Slater
Jamie Young

Production

Rod Cobain
Stephanie Burnett

Marketing

Owen O'Brien
Amy Curtin

Testing & product
support

Russell Alcock
Damian Bradbury
Oliver Marshall

Music and sound effect

David Punshon
Richard Wells

Our special thanks to all the beta testers for their rigorous testing, helpful suggestions and criticisms.

Author's flying experience

Helicopters:

Sea King, Gazelle, Wessex, Jetranger

Fixed wing:

Hawker Hunter

Jet Provost

Hercules

Jetstream

Various light aircraft

Author's engineering experience

Royal Aircraft Establishment, Farnborough:
airborne computer design

Westland Helicopters: Lynx flight control systems
and avionics

A&AEE Boscombe Down: Harrier, Jaguar and
Jetstream flight trials

Royal Aircraft Establishment, Bedford: military
flight simulation





INDEX

A

- Aborting your flight 20
- Afghanistan 16
- Air to air weapons
 - cannon pods 70
 - R60 missile 68
 - turret-mounted machine gun 69
- Air to ground weapons
 - AT-6 'Spiral' missile 62
 - cannon pods 67
 - FAB250 and FAB500 free fall bombs 65
 - FAE-500 fuel air bomb 65
 - KMGU-2 area denial mine dispenser 65
 - OFAB250 blast fragmentation bomb 65
 - Rockets and unguided bombs 63
 - S5 57mm rocket 64
 - S8 80mm rocket 65
 - turret-mounted machine gun 66
- Airspeed indicator. *See* Pilot's Instrument Panel
- Artificial horizon. *See* Pilot's Instrument Panel
- AT-6 'Spiral'. *See* Air to ground weapons
- Autorotation. *See* Emergency procedures

B

- Back. *See* Map tool box
- Barometric altimeter. *See* Pilot's Instrument Panel
- Bombs. *See* Air to ground weapons
- Brake indicator. *See* Pilot's Instrument Panel
- Brakes 53
- Briefing Screen 19

C

- Campaign 9, 16
- Cannon pods. *See* Air to air weapons; Air to ground weapons
- Chaff 74
- Cockpit 29
- Commit button 9
- Control summary. *See* outside back cover
- Controls 12, 52
- Customer support. *See* inside back cover

D

- Debriefing 20
- Debris hemisphere 71
- Delivery techniques
 - Air-to-air missiles 73
 - Mine dispenser 73
 - Rockets 72
 - Unguided bombs 71
- Disable. *See* Map tool box
- Dive bombing. *See* Delivery techniques
- Dynamic rollover. *See* Emergency procedures

E

- Emergency procedures
 - Autorotation 58
 - Dynamic rollover 60
 - Engine failure 60
 - Ground resonance 60
 - Retreating blade stall 60
 - Vortex ring 59
- Ending your flight 20
- Enemy rating 11
- Engine and rotor rpm indicators. *See* Pilot's Instrument Panel
- Engine failure. *See* Emergency procedures

- Engine rpm runaway. *See* Emergency procedures
- Exit 9, 20
- External views 45

F

- FAB250 and FAB500 free fall bombs. *See* Air to ground weapons
- FAE-500 fuel air bomb. *See* Air to ground weapons
- Failure warning lights. *See* Pilot's Instrument Panel
- Fit. *See* Map tool box
- Flares 74
- Flight model 10
- Flight screen 8, 83
- Flightplan restore. *See* Map tool box
- Flightplan save. *See* Map tool box
- Forward Looking Infra Red system 42
- Fuel gauge. *See* Pilot's Instrument Panel

G

- g meter. *See* Pilot's Instrument Panel
- GoTo button 8
- Ground resonance. *See* Emergency procedures
- Gun. *See* Air to ground weapons

H

- Handling modes 49
- Head Up Display
 - Navigation mode 34
 - Weapons mode 36
- Helmet Mounted Sight 40
- Help 8
- History and development of the Hind 85
- Horizontal Situation Indicator. *See* Pilot's Instrument Panel





- I**
- Installation. *See* separate Installation Guide
 - IR jammer 74
- J**
- Joystick configuration. *See* Separate Installation Guide
- K**
- Kazakstan 15
 - Key. *See* Map tool box
 - KMGU-2 area denial mine dispenser. *See* Air to ground weapons
- L**
- Landing gear indicator. *See* Pilot's Instrument Panel
 - Laser designator 42
 - Laydown bombing. *See* Delivery techniques
 - Linking with Apache Longbow. *See* Two player options
 - Loft bombing. *See* Delivery techniques
 - Low light level TV 43
- M**
- Main Screen 7, 8
 - Manoeuvres
 - Forward flight 55
 - Hovering 54
 - Hovering turn 54
 - Landing 56
 - Rolling take-off 57
 - Slowing down to the hover 56
 - Taxiing 57
 - Torque turns 58
 - Transition from hover to forward flight 55
 - Turning in forward flight 56
 - Vertical take-off to the hover 54
- Map Tool Box 21**
- Map tool box
 - 3D 23
 - Back 21
 - Disable 23
 - Fit 21
 - Key 23
 - Met 24
 - Point 23
 - Restore 22
 - Rotate 21
 - Save 22
 - Task 23
 - Way 21
 - Zoom 21
 - Medals 14
 - Met. *See* Map tool box
 - Mine laying. *See* Delivery Techniques
 - Mission planner 11, 21
 - Mission tips 24
 - Modem connection for two player options 76
 - Modem error messages 80
 - Modem set up using a direct link 79
 - Moving map. *See* Pilot's Instrument Panel
- N**
- Natasha system 38
 - Network games
 - Capture The Flag 9, 83
 - Death Match 9, 83
 - Night vision goggles 45
 - North Korea 15

- O**
- OFAB250 blast fragmentation bomb. *See* Air to ground weapons
 - On-line manual 4
- P**
- Pay 24. *See also* Map tool box
 - Pilot's cockpit 30
 - Pilot's Instrument Panel
 - Airspeed indicator 29, 30
 - Barometric altimeter 29, 30
 - Brake indicator 29, 31
 - Engine and rotor rpm indicators 29, 31
 - Failure warning lights 29, 33
 - Fuel gauge 29, 33
 - g meter 29, 31
 - Horizontal Situation Indicator 29, 31
 - Landing gear indicator 29, 31
 - Moving map 29, 32
 - Pitch/Yaw/Roll indicator 29, 30
 - Radar altimeter 29, 30
 - Standby artificial horizon 29, 31
 - Standby compass 29, 33
 - Threat warning indicator 29, 32
 - Vertical speed indicator 29, 30
 - Pilot's instrument panel 29, 30
 - Pilot's Log 7, 8, 13
 - Pitch/Yaw/Roll indicator. *See* Pilot's Instrument Panel
 - Point. *See* Map tool box
 - Preferences 7, 8, 10
 - Promotion 14
- Q**
- Quickstart 5, 7
 - Quit 8

R

R60 missile. *See* Air to air weapons
Radar altimeter. *See* Pilot's Instrument Panel
Recognition 8
Restore. *See* Map tool box
Retreating blade stall. *See* Emergency procedures
Rockets and unguided bombs. *See* Air to ground weapons
Rotate. *See* Map tool box

S

S5 57mm rocket. *See* Air to ground weapons
S8 80mm rocket. *See* Air to ground weapons
Save. *See* Map tool box
Scenario selection 15
Sending in-flight messages in two player games 81
Silicon WSO 39
Single missions 16
Sound 11
Standby artificial horizon. *See* Pilot's Instrument Panel
Standby compass. *See* Pilot's Instrument Panel

T

Task. *See* Map tool box
Threat warning indicator. *See* Pilot's Instrument Panel
Time compression 53
Top ten 6
Training 8, 71
Turret optics 44
Turret-mounted machine gun. *See* Air to air weapons; Air to ground weapons

Two player options
 across a network 81
 Combat 75
 Pilot / WSO 75
 Single missions 75
Two player set up 76

U

Undercarriage 53

V

Vehicle inventory 89
Vertical speed indicator. *See* Pilot's Instrument Panel
Views. *See* External views
Visual detail 10
Vortex ring. *See* Emergency procedures

W

Way. *See* Map tool box
Waypoint types 19
Waypoint window 21
Weapon management panels 40
Weapon System Operator's cockpit 39
Wingman and formation control 28

Z

Zoom. *See* Map tool box





14. CUSTOMER SUPPORT

If you have any questions about Hind or any of our other products, please contact our Customer Support at:

write: Sold Out Software Ltd.
Unit 308
The Chandlery
50 Westminster Bridge Road
London
SE1 7QY

phone: 0171 721 8767
fax: 0171 721 7453
email: webmaster@sold-out.co.uk

Or simply visit Hind's developer's website, at:
www.digint.co.uk

If you require technical support, please call the above number, not our sales line. Please have the following details to hand:

- Name & Address
- Product name
- Computer hardware configuration
- Description of problem
- Error messages appearing on screen, if any.

Faulty items

If you purchased Hind direct from Sold Out and you are unhappy with the product for any reason, it is our company policy to offer an exchange or refund your purchase price, less the cost of postage and packing. This offer is subject to the goods being returned to us in a resaleable condition within 14 days of purchase. If you are having trouble with the installation then please write to or call our Customer Support. If you suspect that the CDROM is faulty, please return it direct to us (not via your retailer) and we will send you a tested replacement free of charge. Please include the name and address of your supplier.

We regret that it is not possible for us to offer a refund if the product was not purchased from Sold Out. In such cases, your request must be addressed to the retailer. Your normal consumer rights are not affected by this policy.



PRIMARY FLIGHT CONTROLS

Cyclic forward	W
Cyclic backward	Z
Cyclic left	A
Cyclic right	S
Collective up	Q or +
Collective down	A or -
Collective presets (10 to 100%)	1 to O
Tail rotor left	Z or i
Tail rotor right	X or d

COCKPIT CONTROLS

HUD contrast adjust	I
Instrument lights	L
Select next waypoint	N
Select previous waypoint	S N
Night vision on/off	V
Under-carriage up/down	U
Cargo doors open/close	D
Brakes	B
Transmit Reconnaissance data	R

WEAPONS CONTROLS

Arm and select weapon	E
Unarm weapon	c E
Fire weapon	z
Auto chaff on/off	C
Auto flare on/off	F

COCKPIT VIEW CONTROLS

Pilot front view	2 or h
WSO front view	3 or u
Look left & right	a A or S
Re-centre view	j
*FLIR/LLTV optics view	O (a + cyclic to steer aiming reticle)
*Turret optics	G

(*WSO cockpit only)

EXTERNAL VIEW CONTROLS

Hind external view	6
Weapon view	7
Weapon target view	8
Target lock view	9
Remote view	O
Spectator view	-
Drone watch (next)	=
Drone watch (previous)	S =
Rotate view	a A or S
Zoom in	>
Zoom out	<

SILICON WSO

Rescan targets	B
Silicon WSO on/off	S
Track target	T

WINGMAN MESSAGES

	Wingman Formation		
Go home	c	S	1
Follow me	c	S	2
Attack my target/help me	c	S	3
Resume Flightplan	c	S	4

VISUAL DETAIL

Lowest detail	a	1
Medium detail	a	2
Full detail	a	3
Visual range	a	1 to 7

MISCELLANEOUS CONTROLS

End mission	c	Q
Pause/resume	P	
Select time compression	T	
Cancel time compression	c	T
		or q
Joystick on/off	c	J
Joystick recalibrate	a	J

On-screen manual S 1

2 player message keys c 1 to O
(see chapter 9 in the manual for the messages)